

# -40-8

Montageanweisung / Installation instructions / Instruction de montage / Istruzioni di montaggio  
montagehandleiding / Instrukcja montażu / Montaj talimatlar / Osszeszerelési útmutató / Nàvod k montáži /  
Nàvod na montáž / Instrucțiune de montaj / инструкции по сборке / Montaj talimatina / Monteringsanvisningar/  
Upute za montažu / Instrucciones de Montaje / Navodila za montažo

# SWING

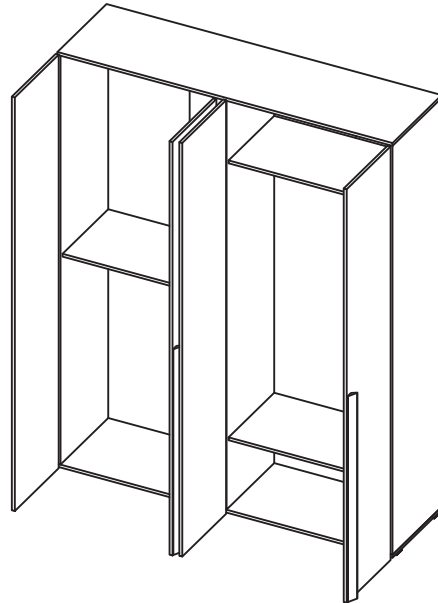
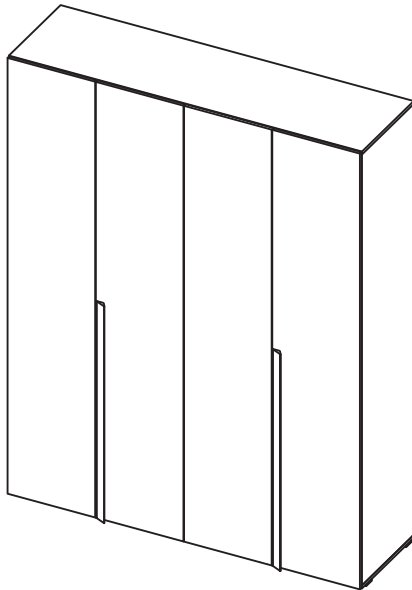
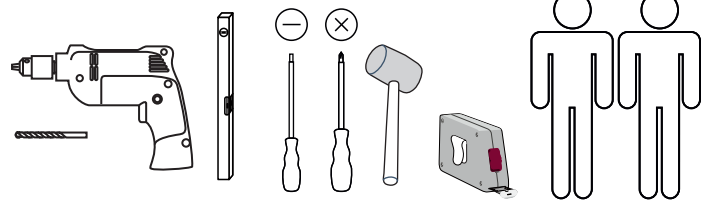
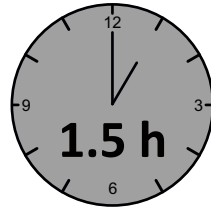

**De** – bitte lesen sie diese montageanleitung gut durch,  
Da wir für fehler, die durch falsche montage entstehen,  
Keine haftung übernehmen!

**Gb** – please read these installation instructions  
Through carefully as we cannot accept any liability  
For faults occurring as a result of incorrect installation!

**Cz** – přečtěte si prosim pozorně tento návod k montáži,  
Aby jste předešli chybám vzniklých špatnou montáží,  
Za které neručíme!

**Fr** – veuillez lire attentivement cette notice de montage,  
Car nous déclinons toute responsabilité en cas d'erreurs  
Découlant d'un montage erroné !

**It** – prego leggere attentamente le istruzioni per il montaggio,  
Poiché decliniamo qualsiasi responsabilità  
Per difetti derivanti da montaggio errato.

**Se** - läs monteringsanvisningarna noggrant.  
Vi avsäger oss allt ansvar för defekter som  
Uppstår p.g.a. Felaktig montering.

**Rs** – pažljivo pročitajte upute za montažu,  
Jer otklanjamo svaku odgovornost za pogreške  
Nastale uslijed pogrešne montaže.

**Sl** – prosimo, da pazorno preberete navodila za montažo,  
Saj zavračamo vsakršno odgovornost za napake,  
Ki bi nastale zaradi napačne montaže.

**Pt** – leia atentamente as instruções de montagem, uma vez  
que não assumimos qualquer responsabilidade por defeitos  
resultantes de uma montagem incorrecta.

**Nl** – leest u alstublieft deze montagehandleiding goed door,  
Voor fouten door verkeerde montage zijn wij niet verantwoordelijk.

**Pl** – prosze uwaznie zapoznac sie z instrukcja montazu,  
Poniewaz nie ponosimy odpowiedzialnosc za niewlasciwy montaz.

**Hu** – Kérjük, olvassa el figyelmesen  
ezt az összeszerelési útmutatót,  
mert a helytelen összeszerelésből  
a dódó hibákért nem vállalunk felelősséget!

**Sk** – Prosime, dobre prečítajte si tento návod na montáž,  
pretože nepreberáme žiadne ručenie za chyby,  
ktoré vzniknú na základe chybnej montáže!

**Ro** – Vă rugăm să cititi cu atenție aceste instrucțiuni  
de montaj deoarece nu preluăm garanția pentru defecte  
ce apar datorită unui montaj incorect!

**Ru** – Пожалуйста, внимательно ознакомьтесь ù  
с данной инструкцией по монтажу, поскольку мы не  
несем ответственности за ошибки, причиной которых  
является неправильный монтаж.

**Tr** – İlkonce kullanma klavuzunu iyi okuyun,  
yalnis montaj yapasaniz bunun sorumlusu biz degiliz.

**Es** – Se ruega leer con atención las instrucciones  
de montaje debido a que declinamos cualquier  
responsabilidad  
por defectos derivados de un montaje erróneo.

# SWING

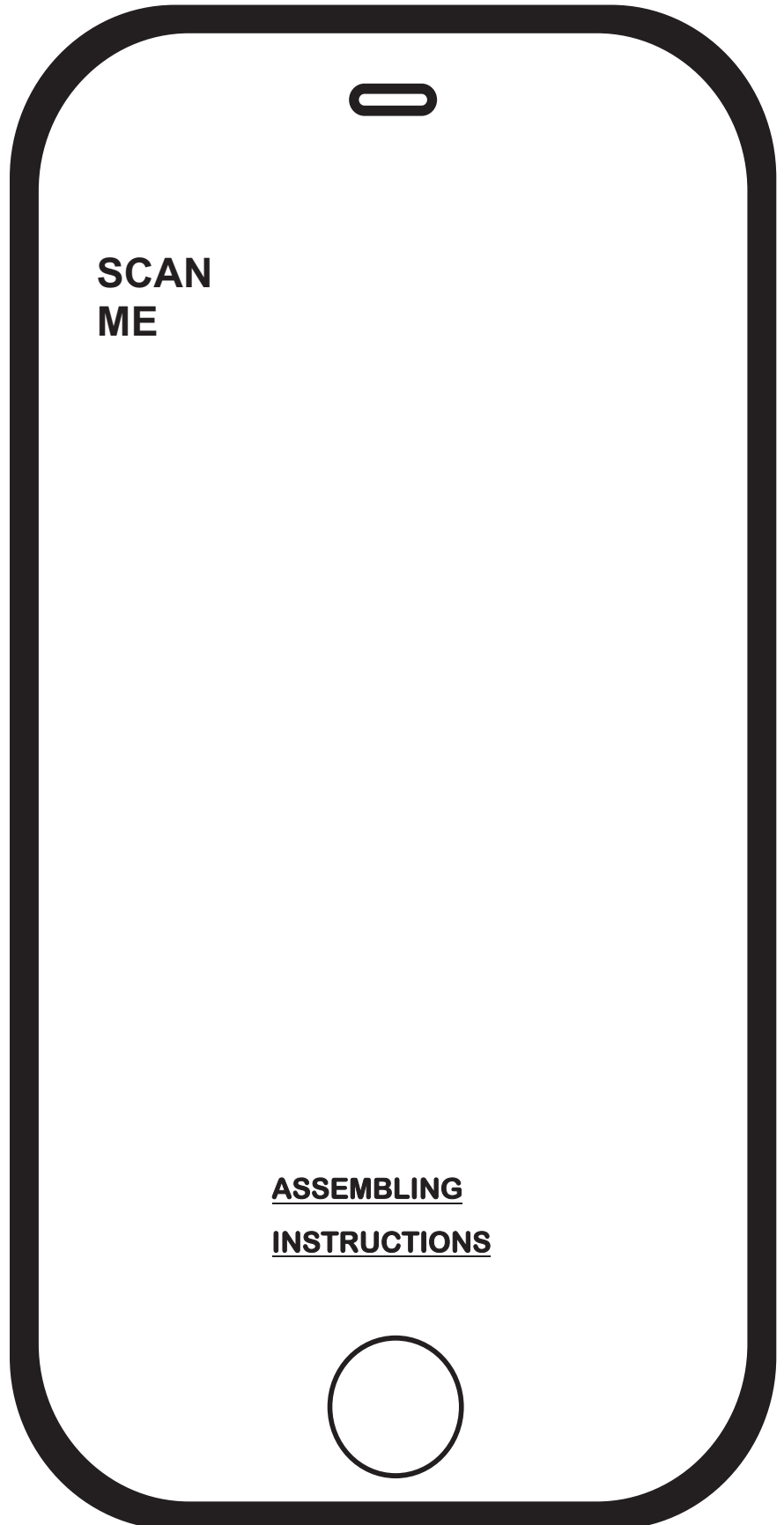

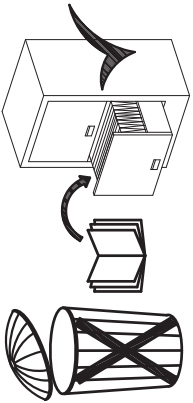

OK

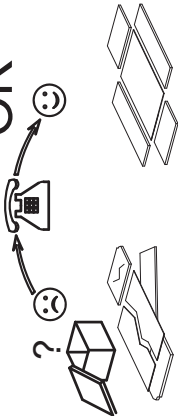

**60FI**

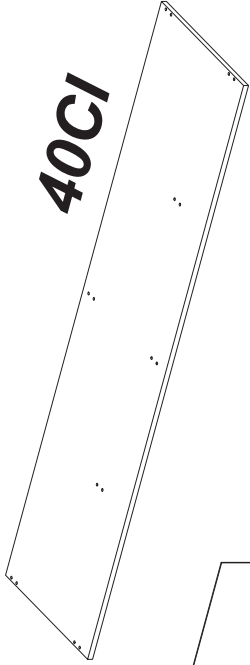
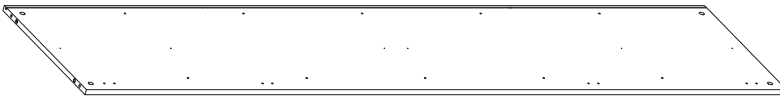

**40CI**

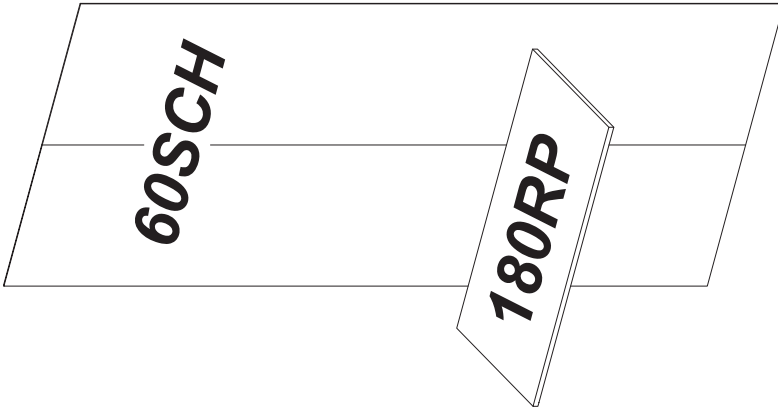

**60SCH**

**180RP**

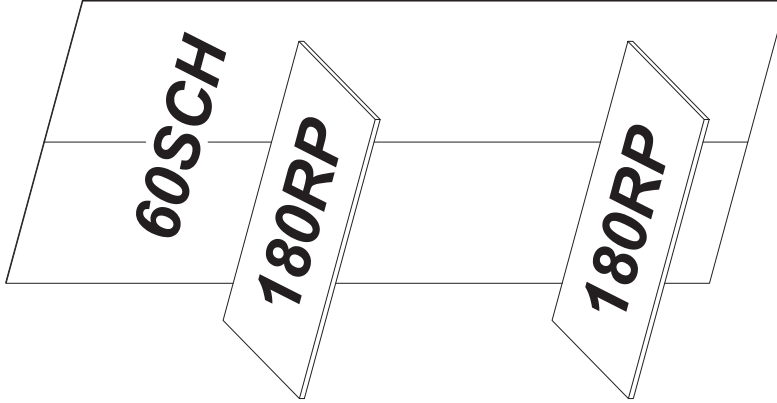

**60SCH**

**180RP**

**180RP**



**60TR**

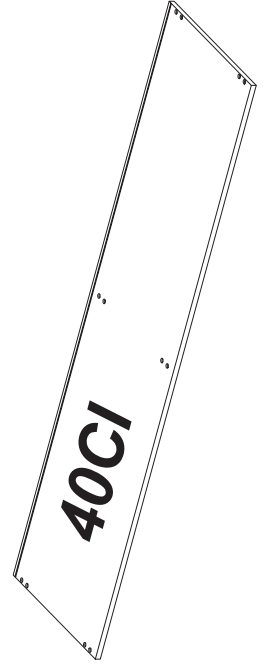

**40CI**

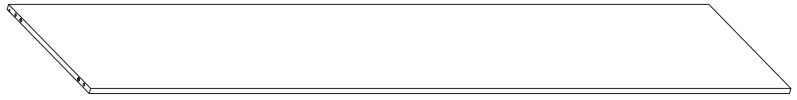

**60FI**



**60SP**

**x 4**

**ONDERDELEN LYST-SERVICEKARTE-FORMULAIRE DEMANDES SAV-SPAREPARTS LIST-SCHEDADI SERVIZIO**

BESLAG-BESCHLAEGE - QUINCALLERIE - HARDWARE - FERRAMENTA

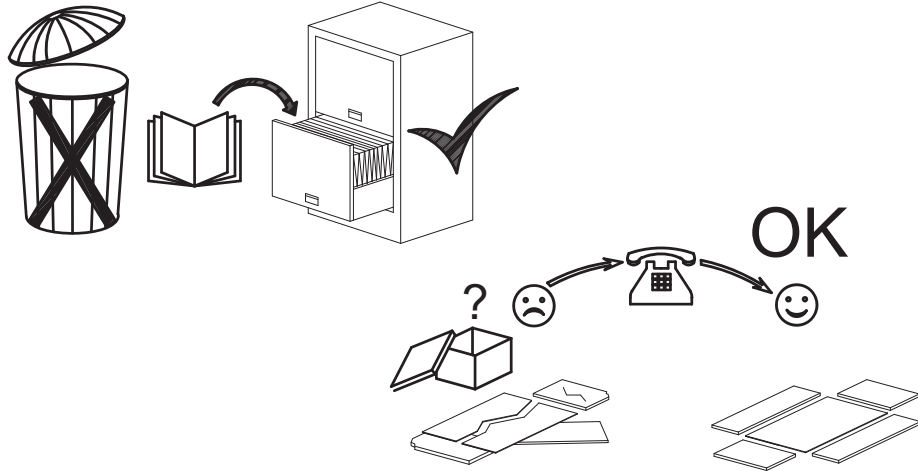

**H2T**

**x16**

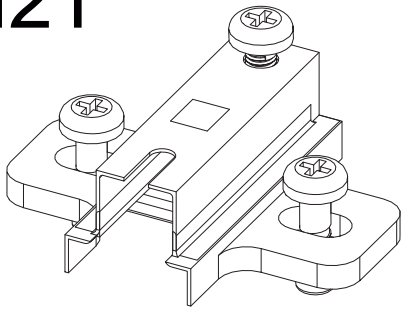

**V415**

**x32**

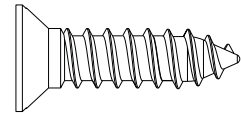

Ø4x15 mm

**C8**

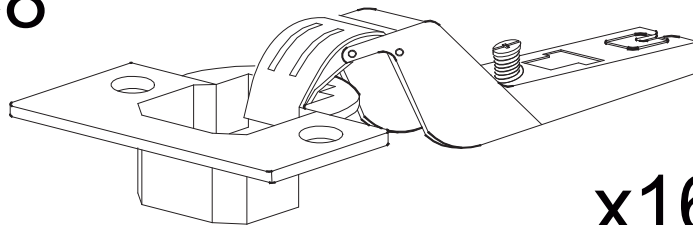

**x16**

**MAN** **x2**

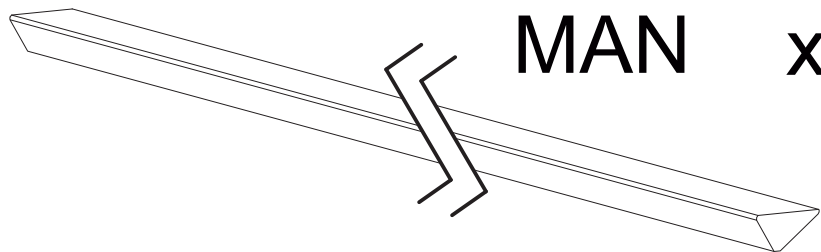

**TUB**

**x3**

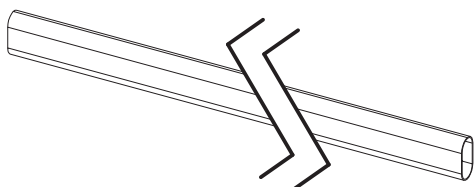

**RT**

**x6**

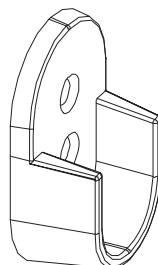

**B**

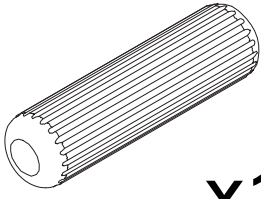

**x12**

**C**

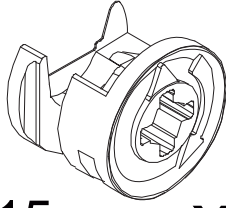

ø15

**x12**

**D**

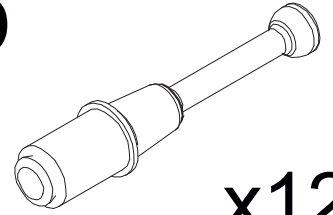

**x12**

**P**

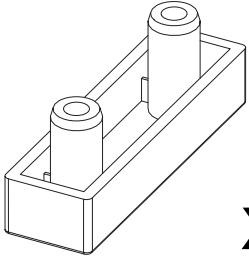

**x8**

**R**

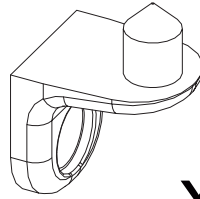

**x12**

**M9**

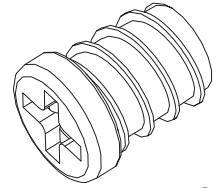

ø6x9 mm

**x12**

**L**

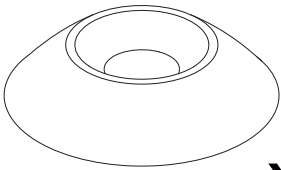

**x6**

**G**

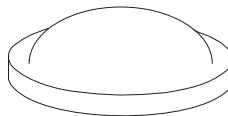

**x8**

**F**

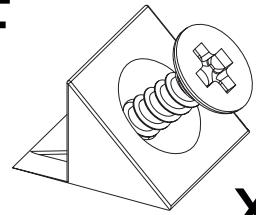

**x16**

**V3516 x14**

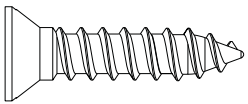

ø3.5x16 mm

**V420 x16**

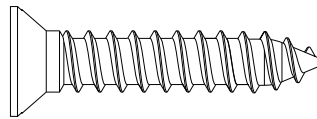

ø4x20 mm

**PST x1**

**V3525 x6**

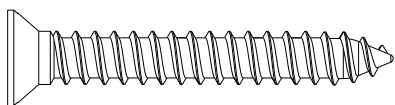

ø3.5x25 mm

**T422 x8**

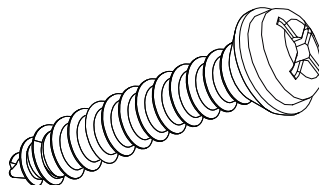

ø4x22.5 mm

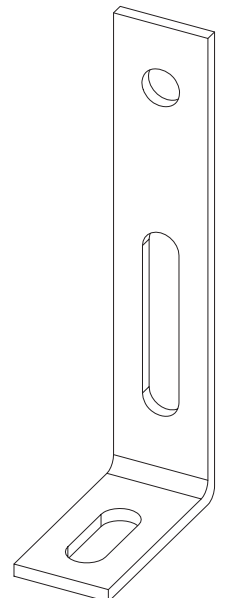

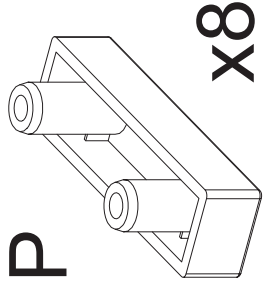

**x8**

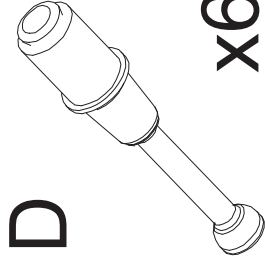

**x6**

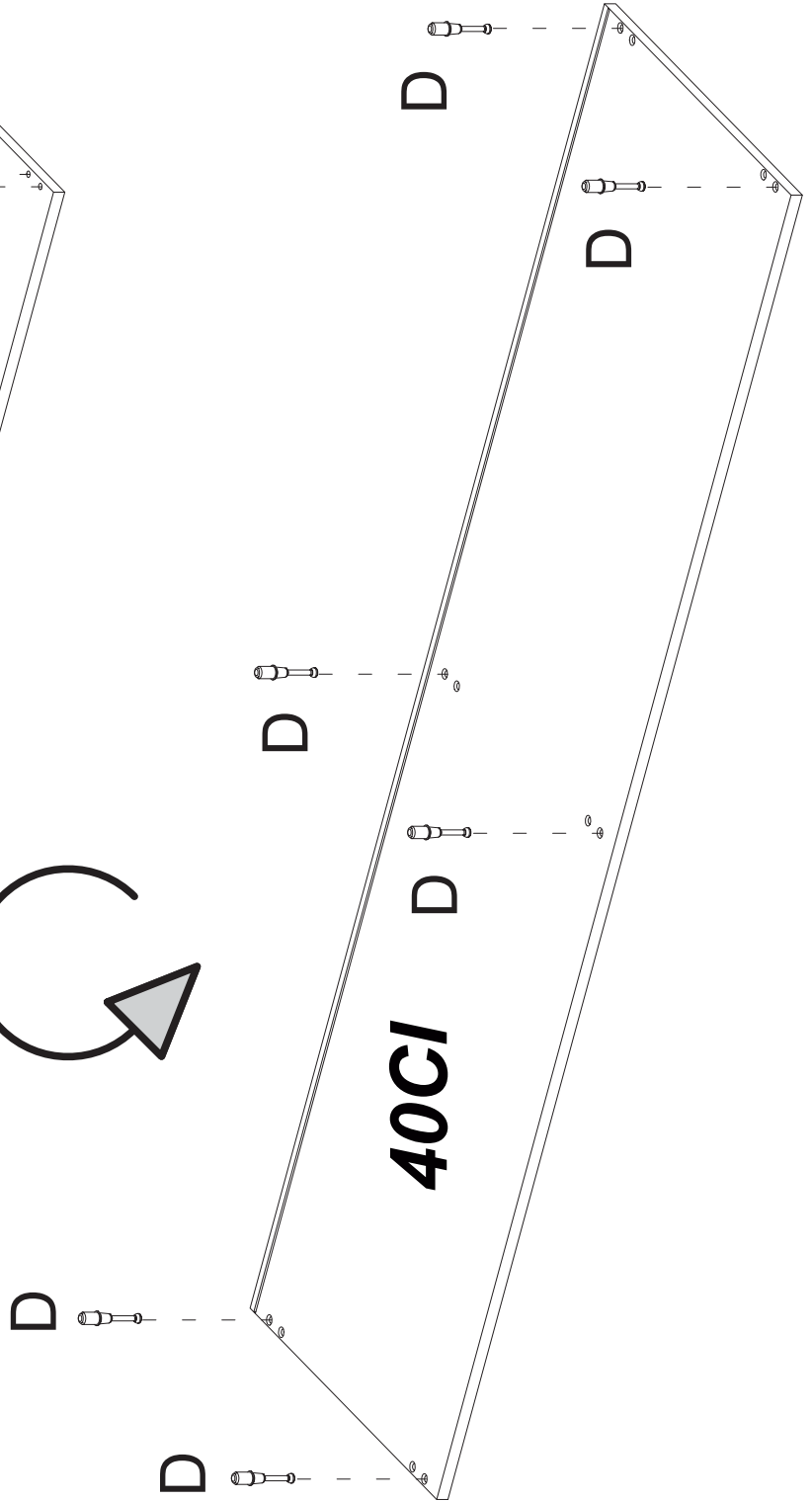
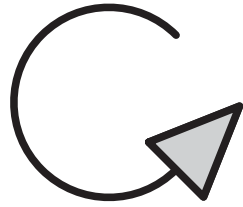
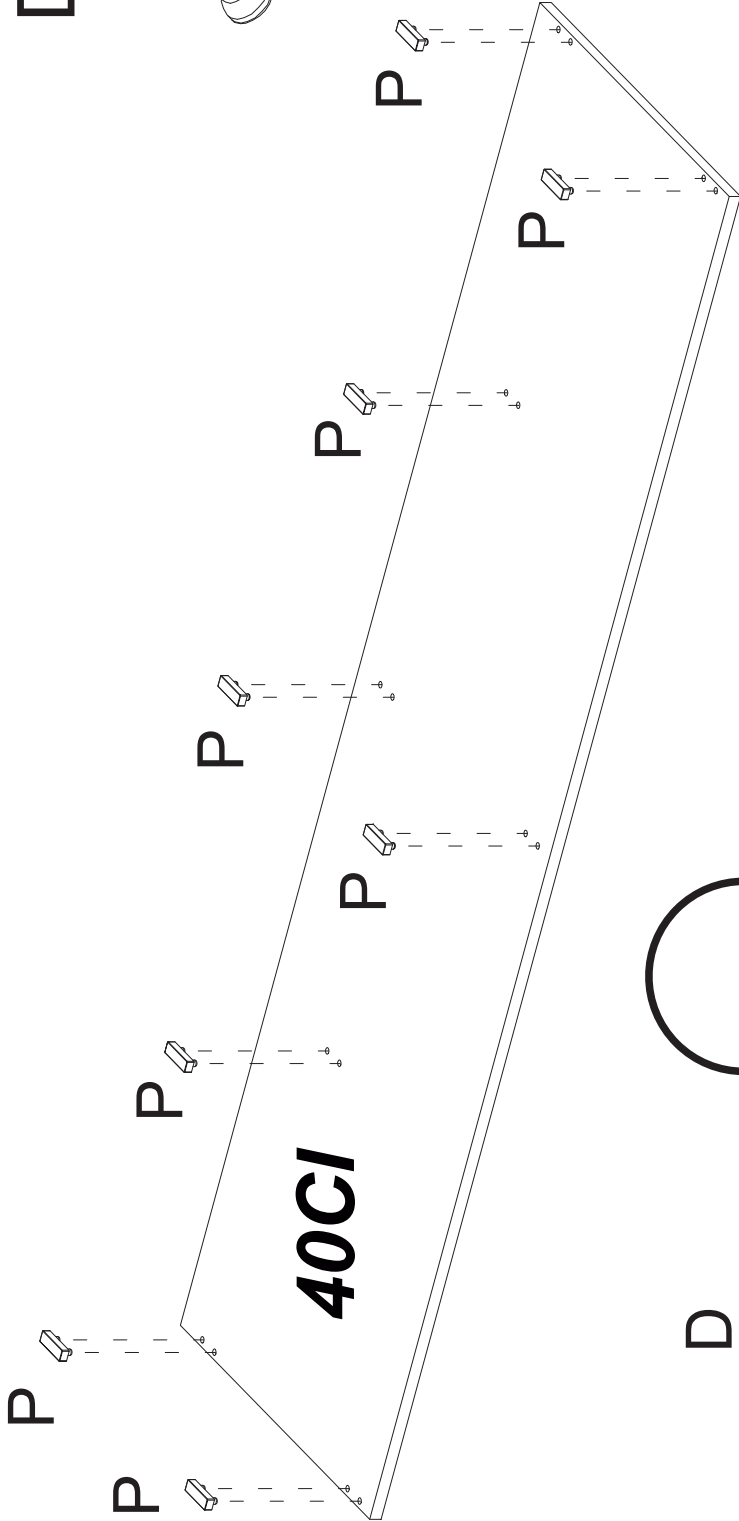
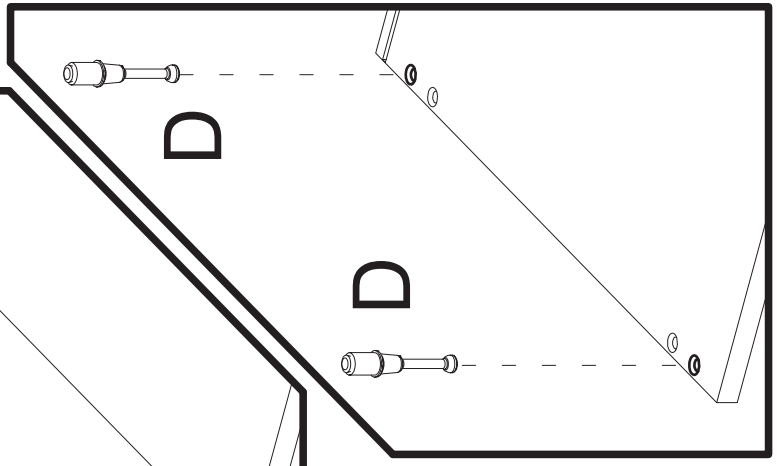
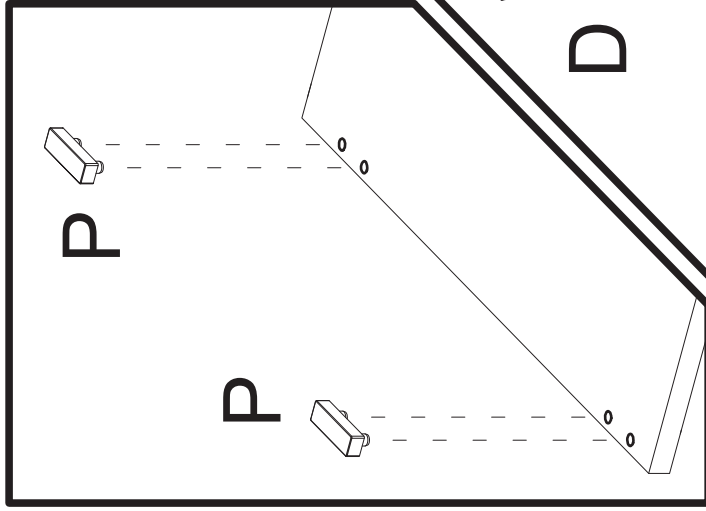

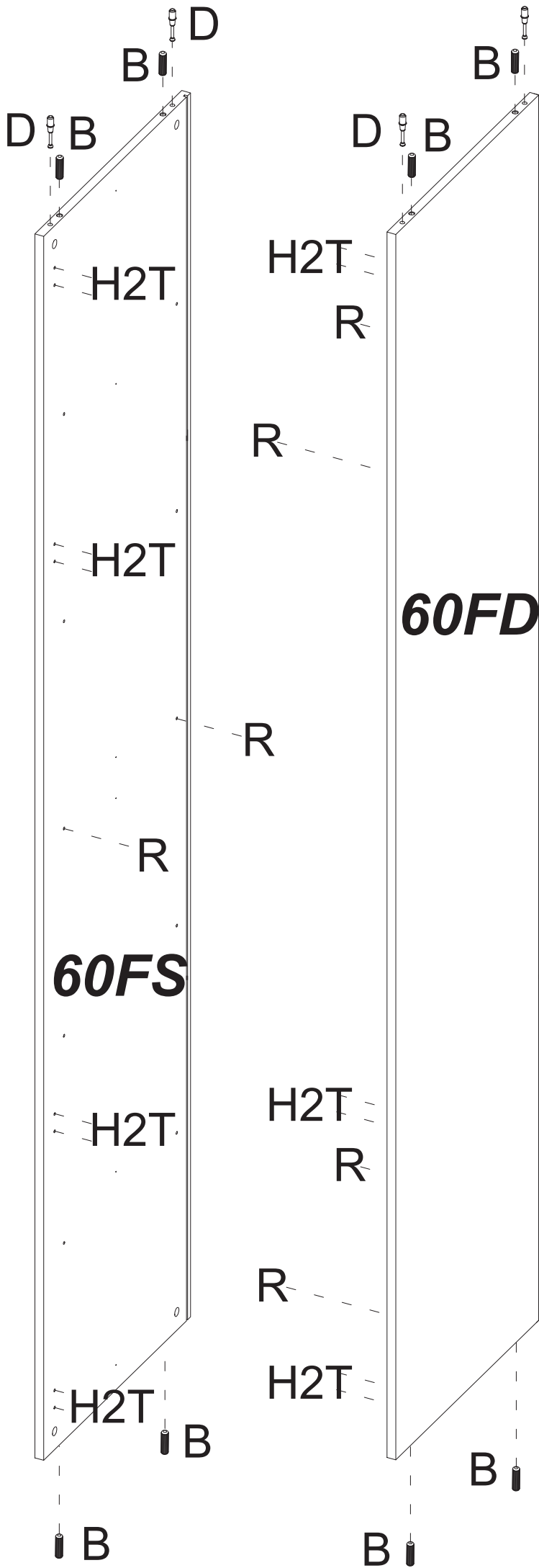

- B** x8
- D** x4
- H2T** x8
- R** x6
- M9** x6
- V420** x8
- Ø4x20**

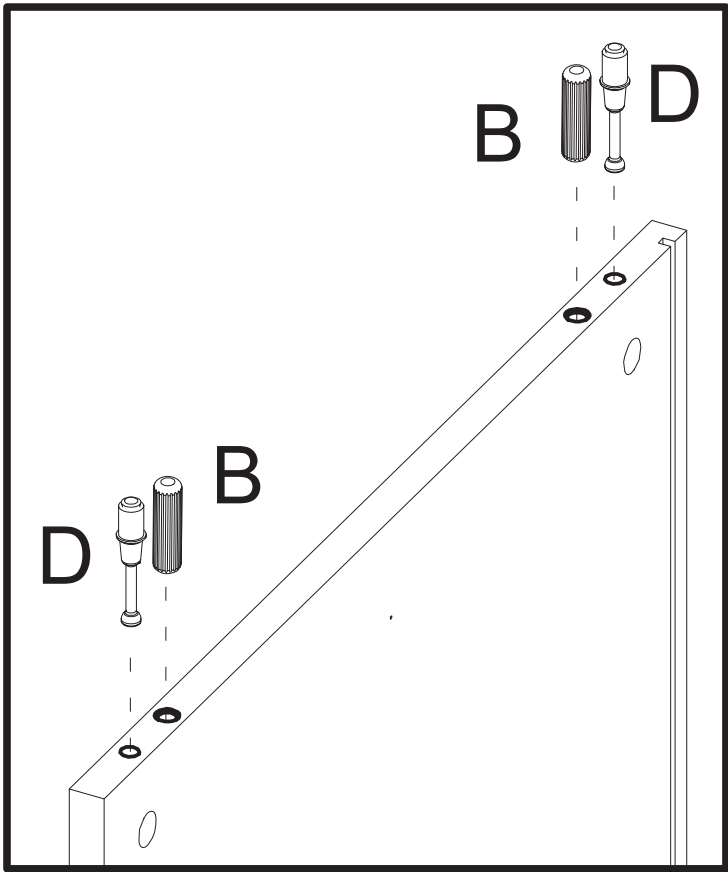
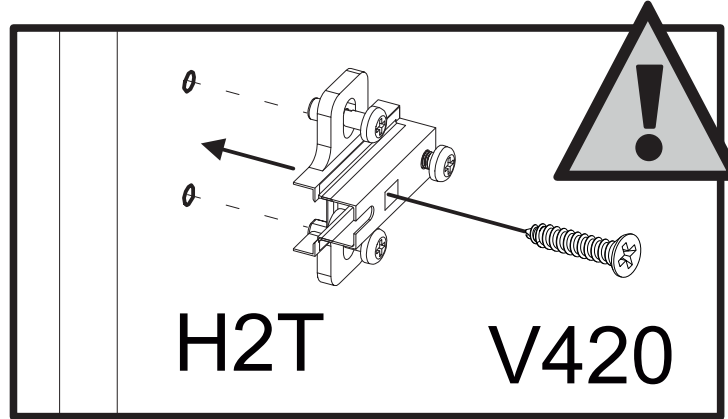
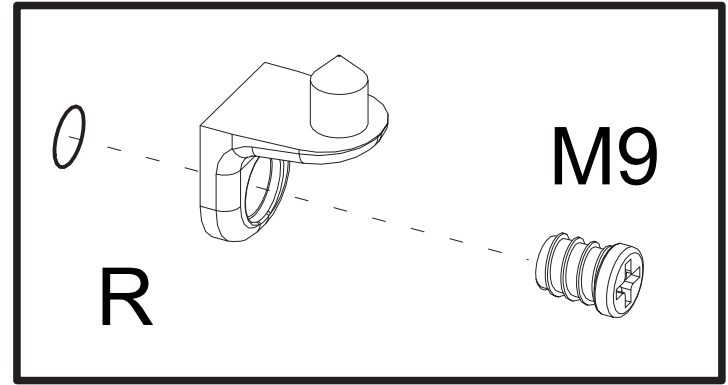

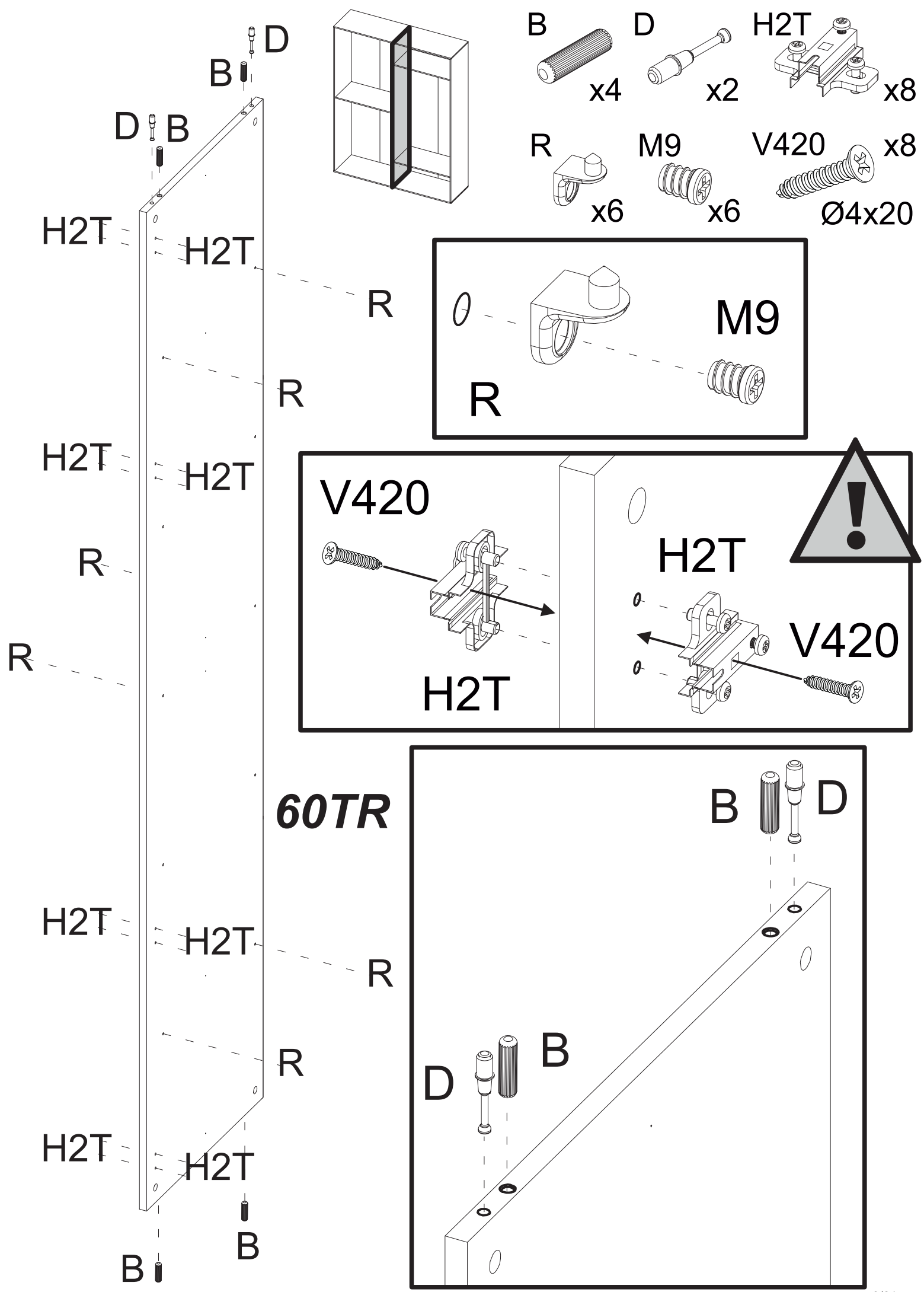

1

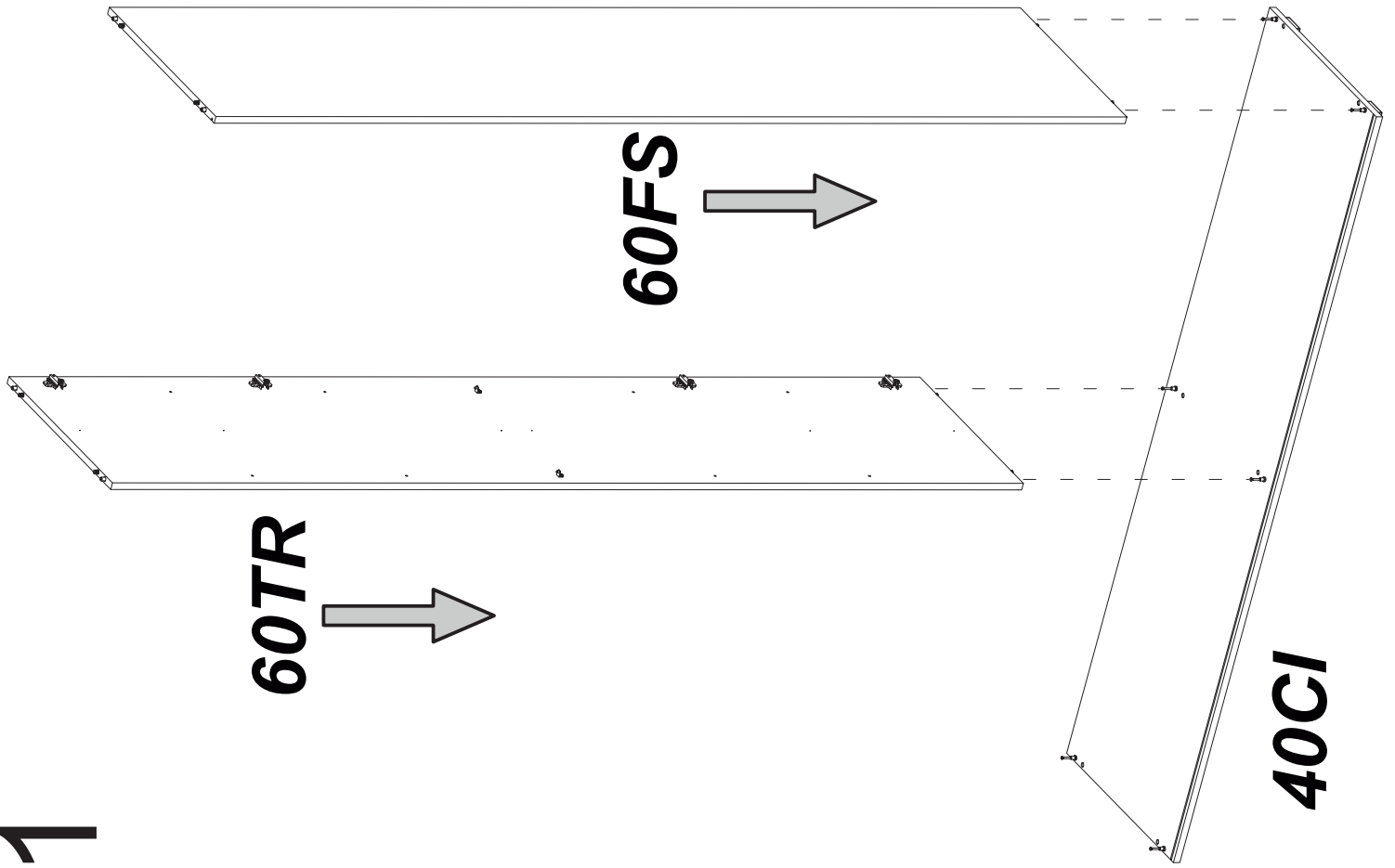

2

**C**  
ø15 X4

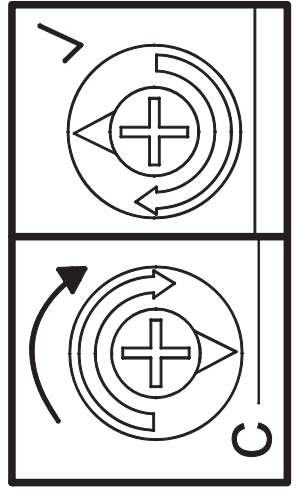
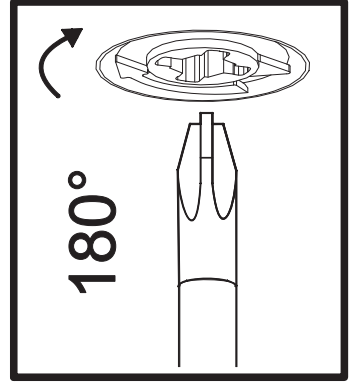
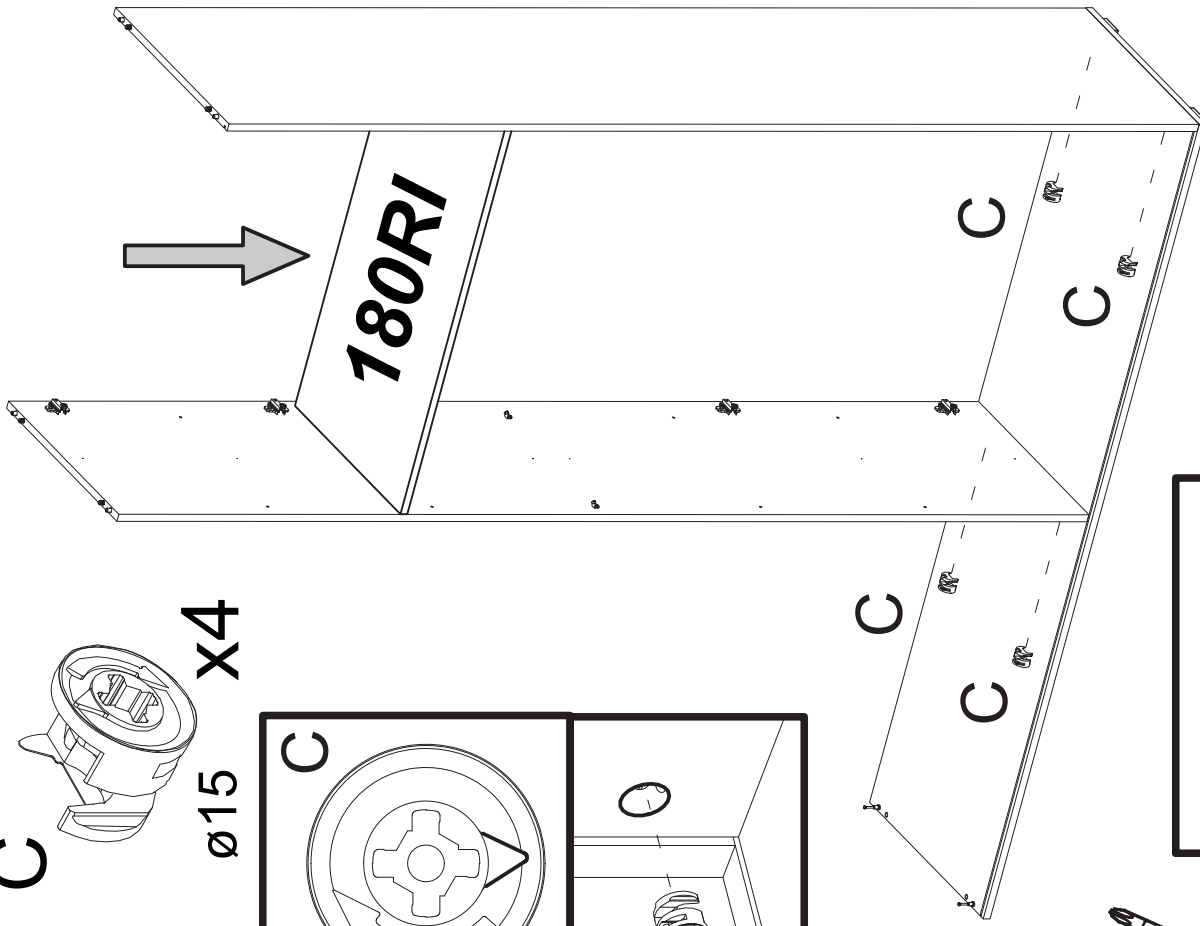
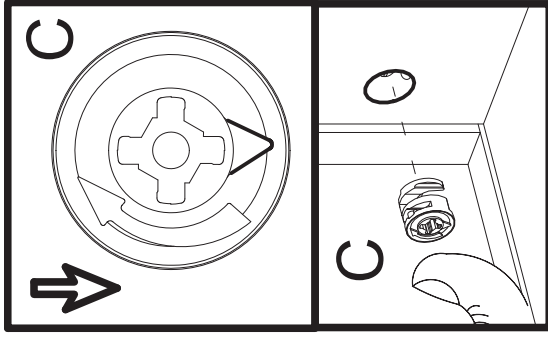
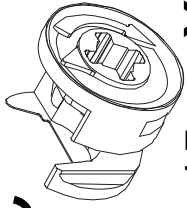

3

60SCH

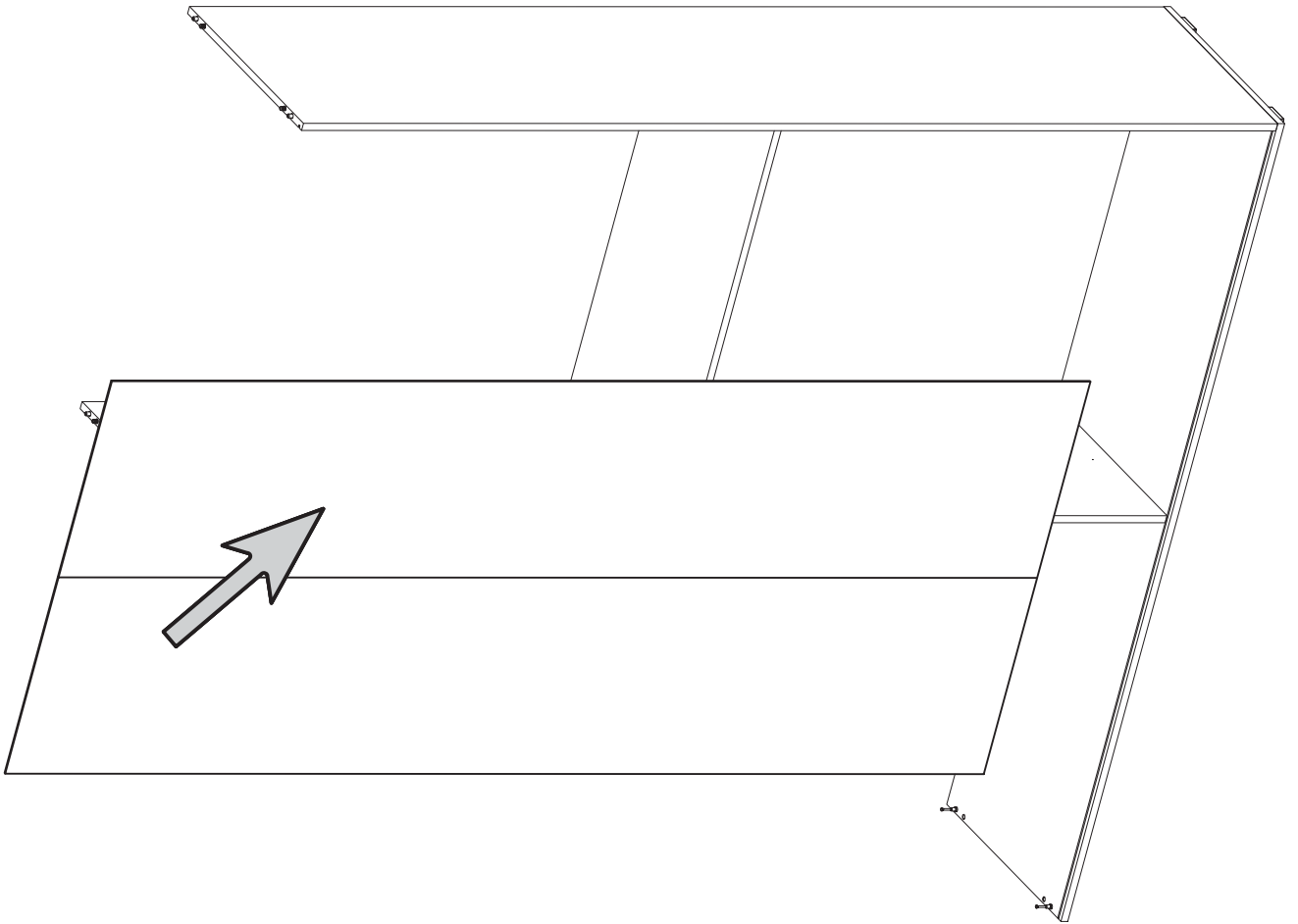

4

F

x2

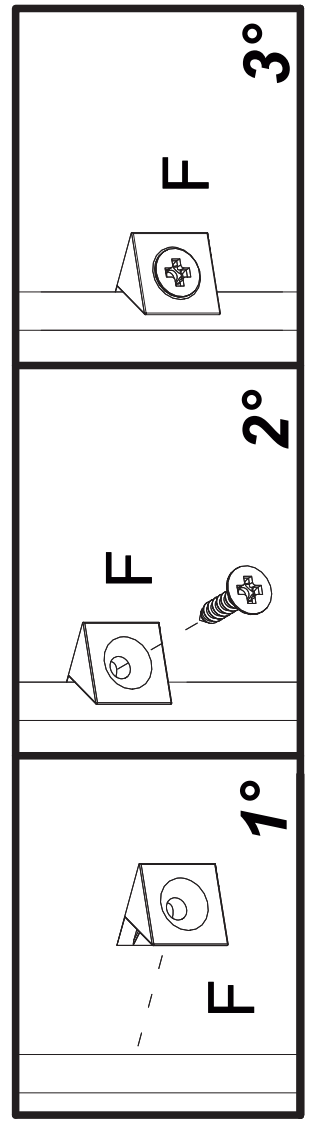
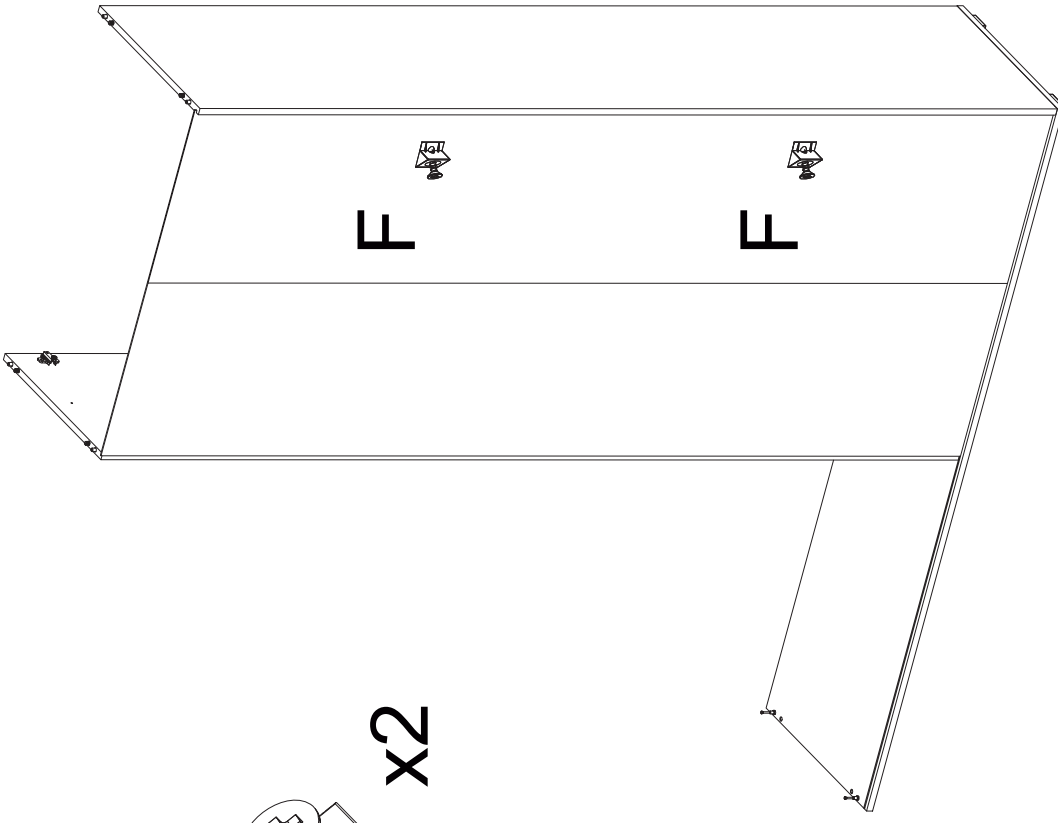
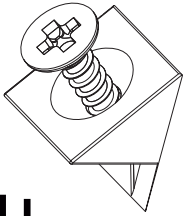

**5**

**60FD**

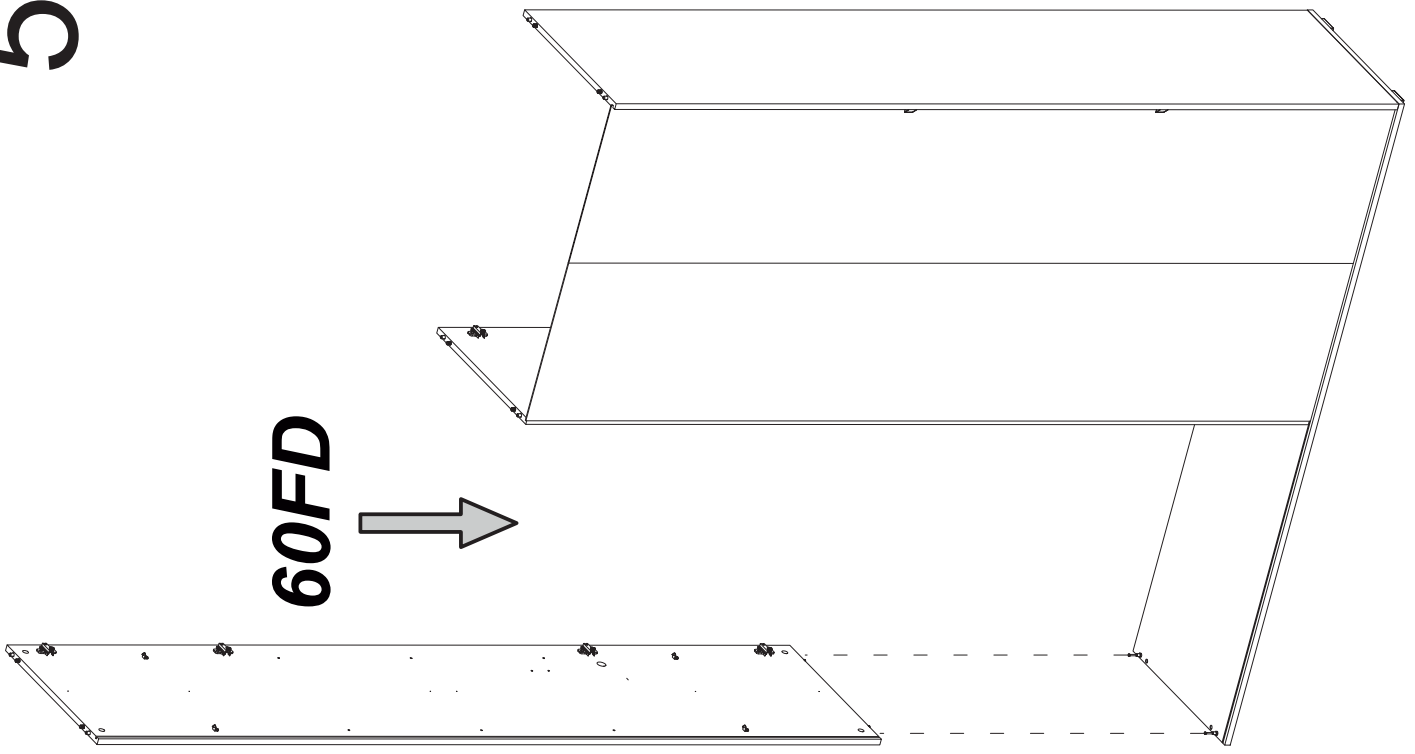
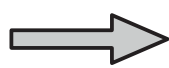

**180RI x 2**

**C**

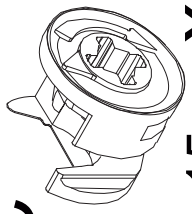
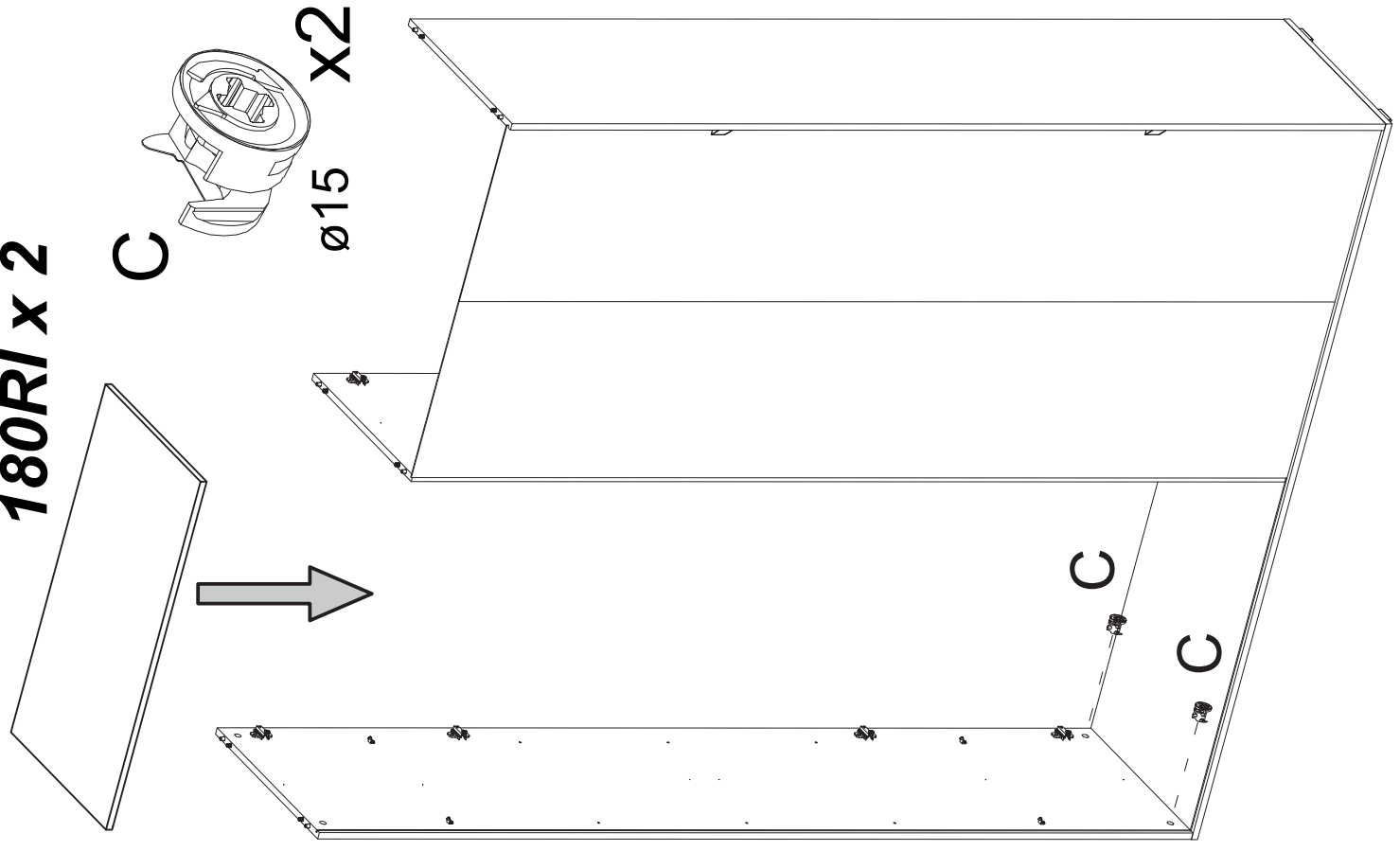
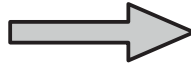

**ø15 X2**

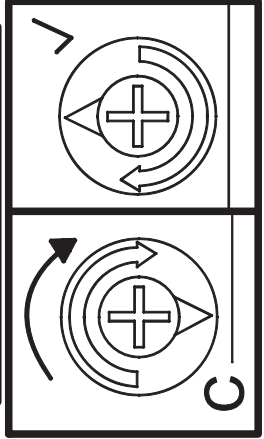
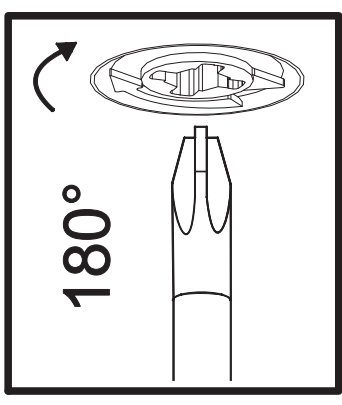
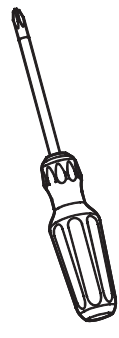
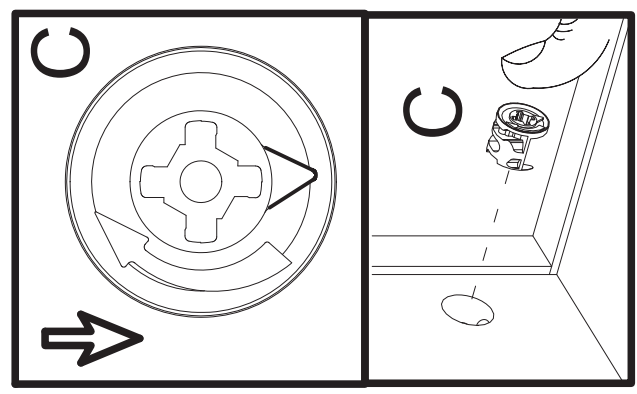

7

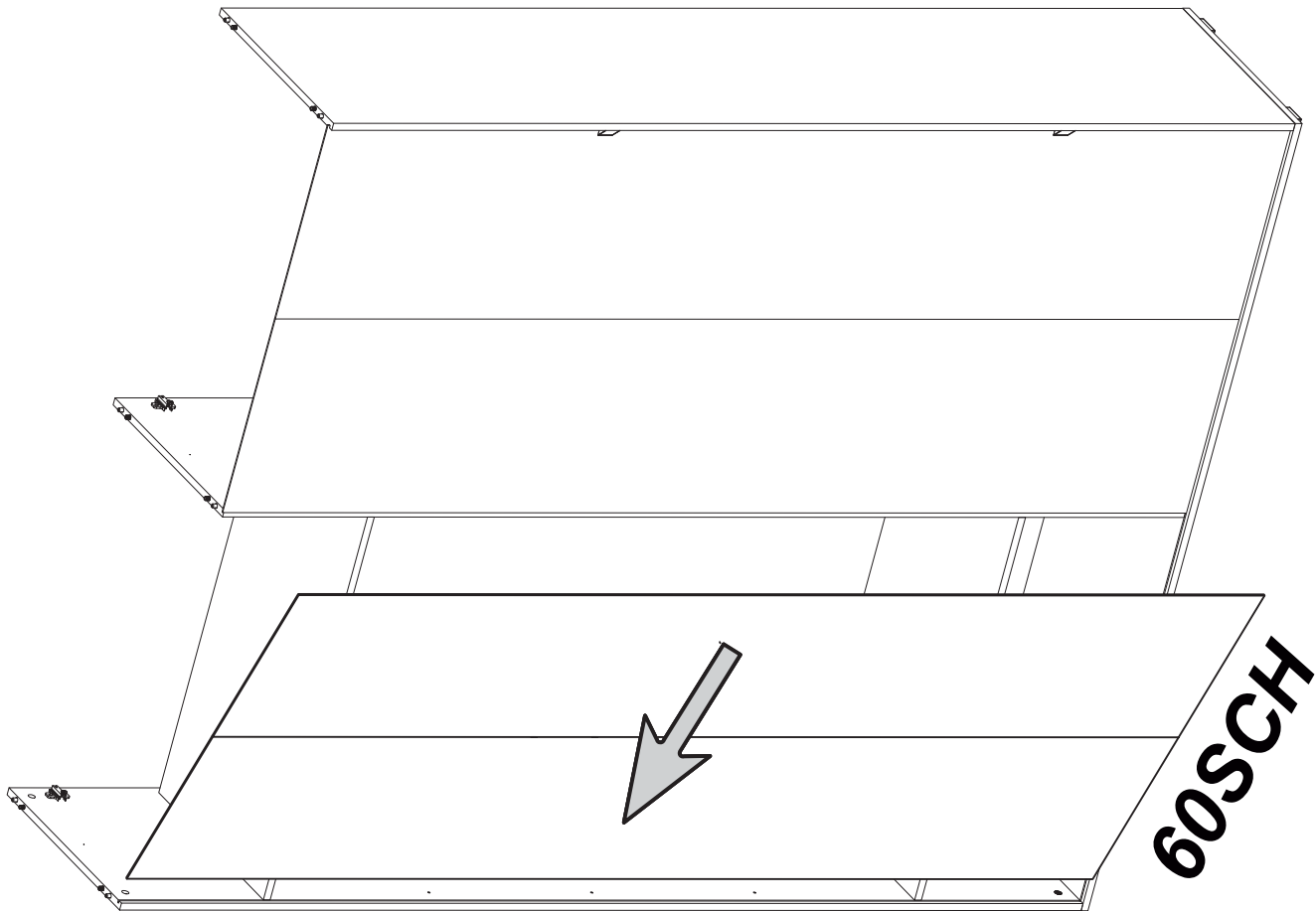

8

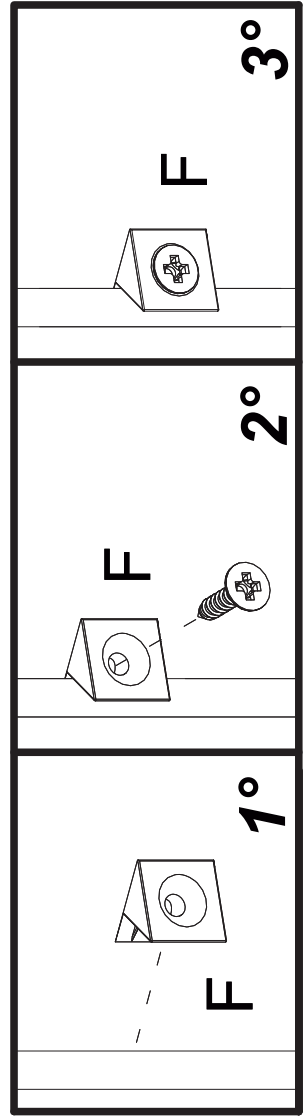
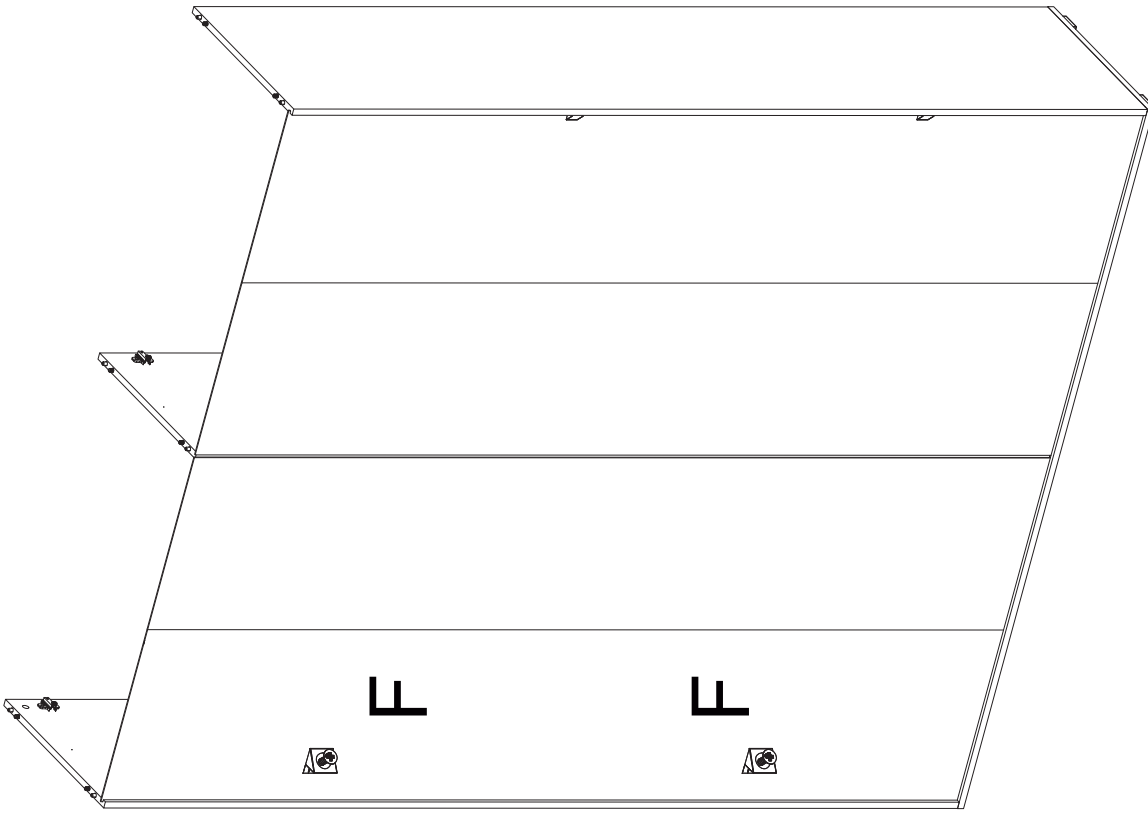
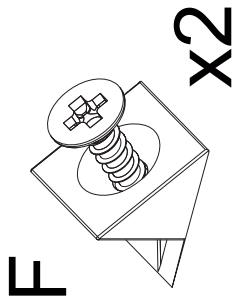

9

**40CI**

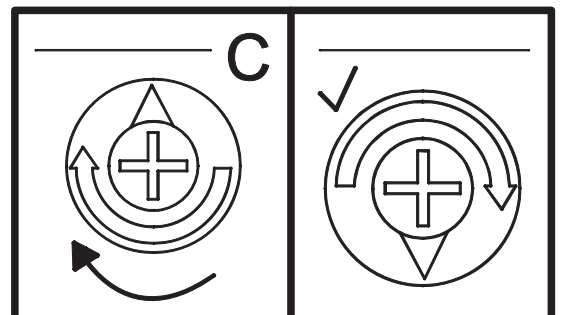
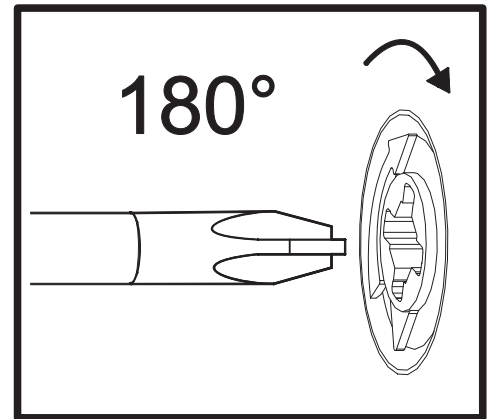
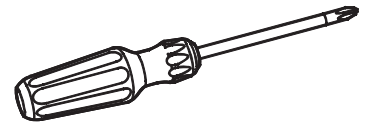
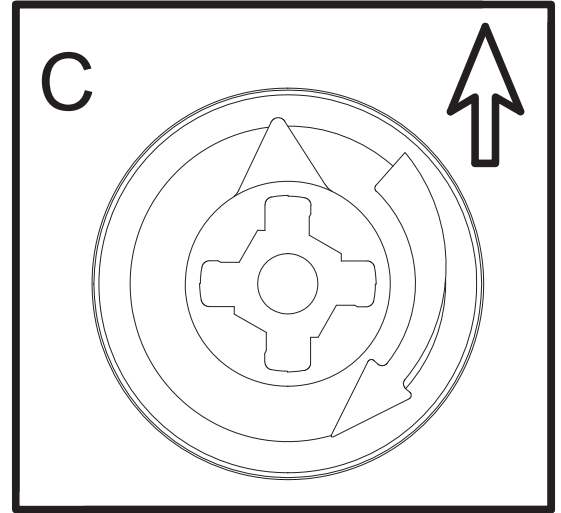
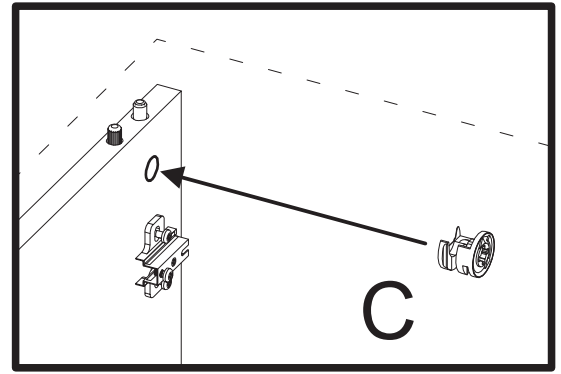
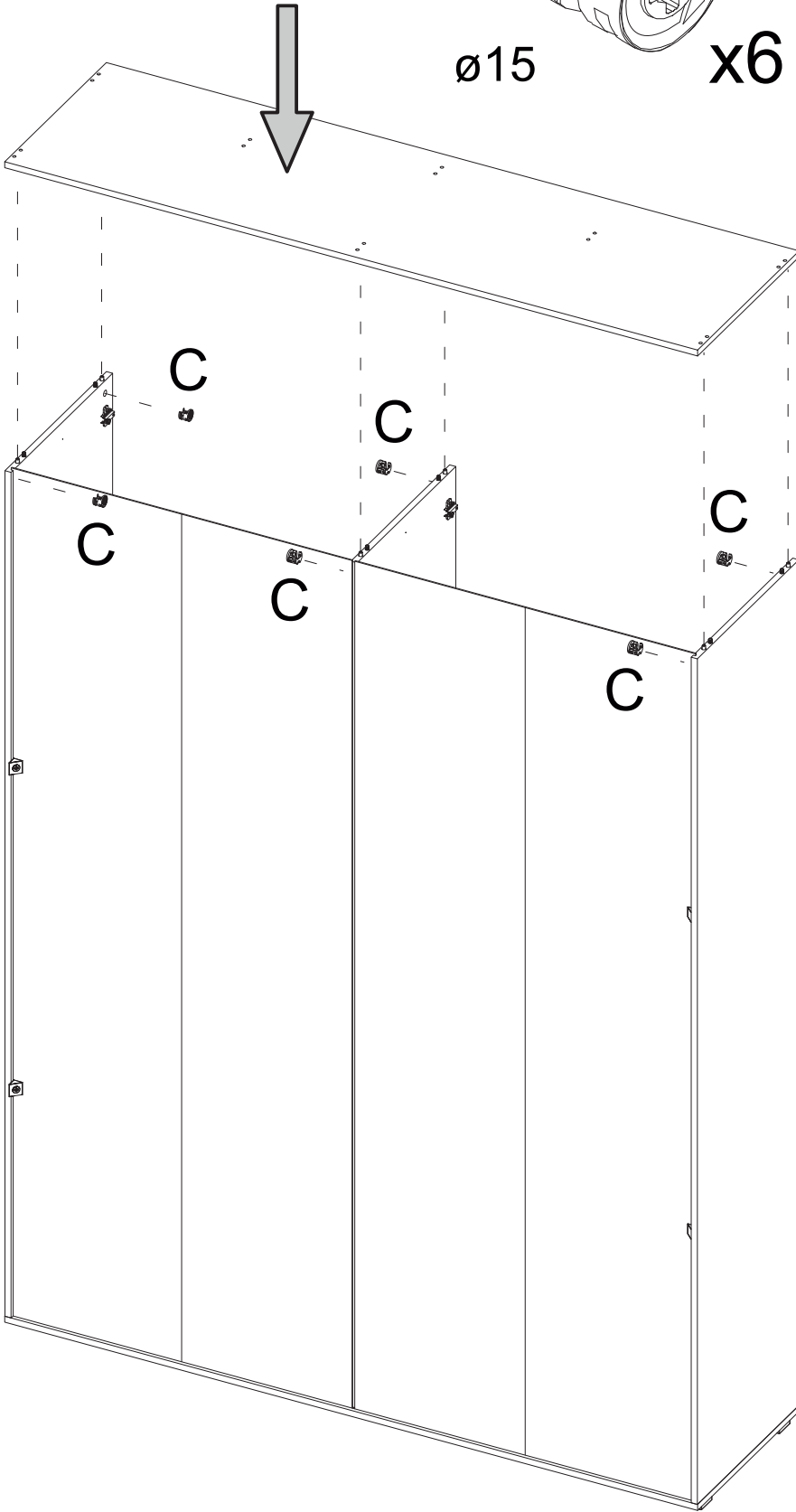
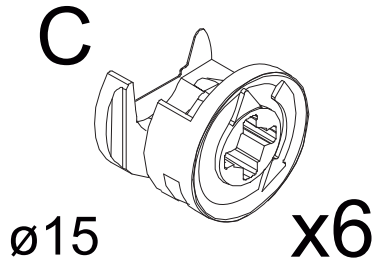

10

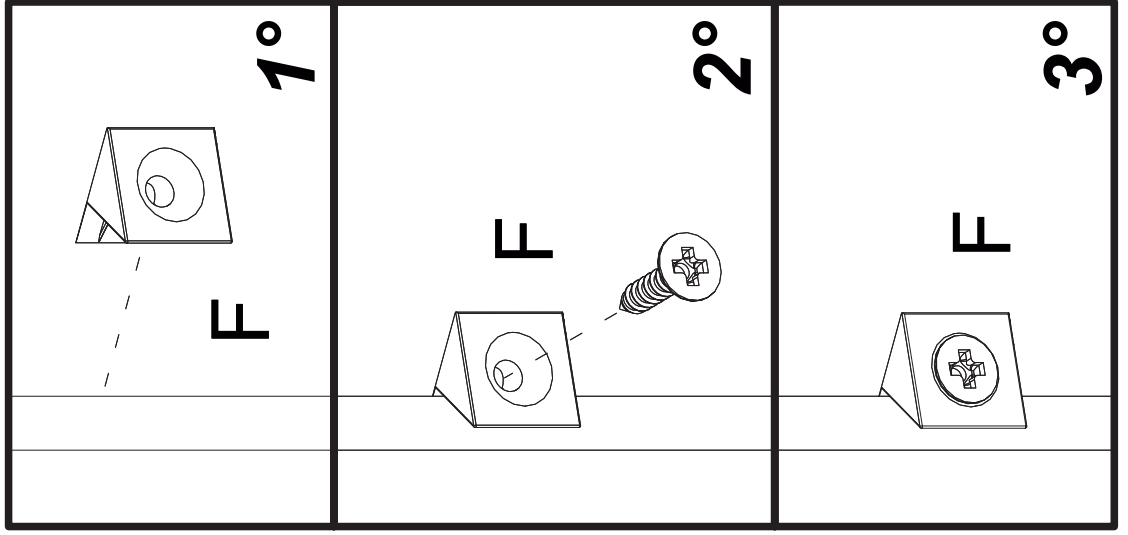
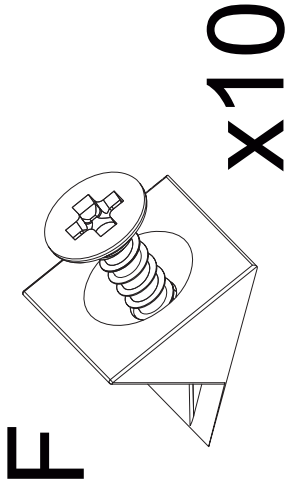
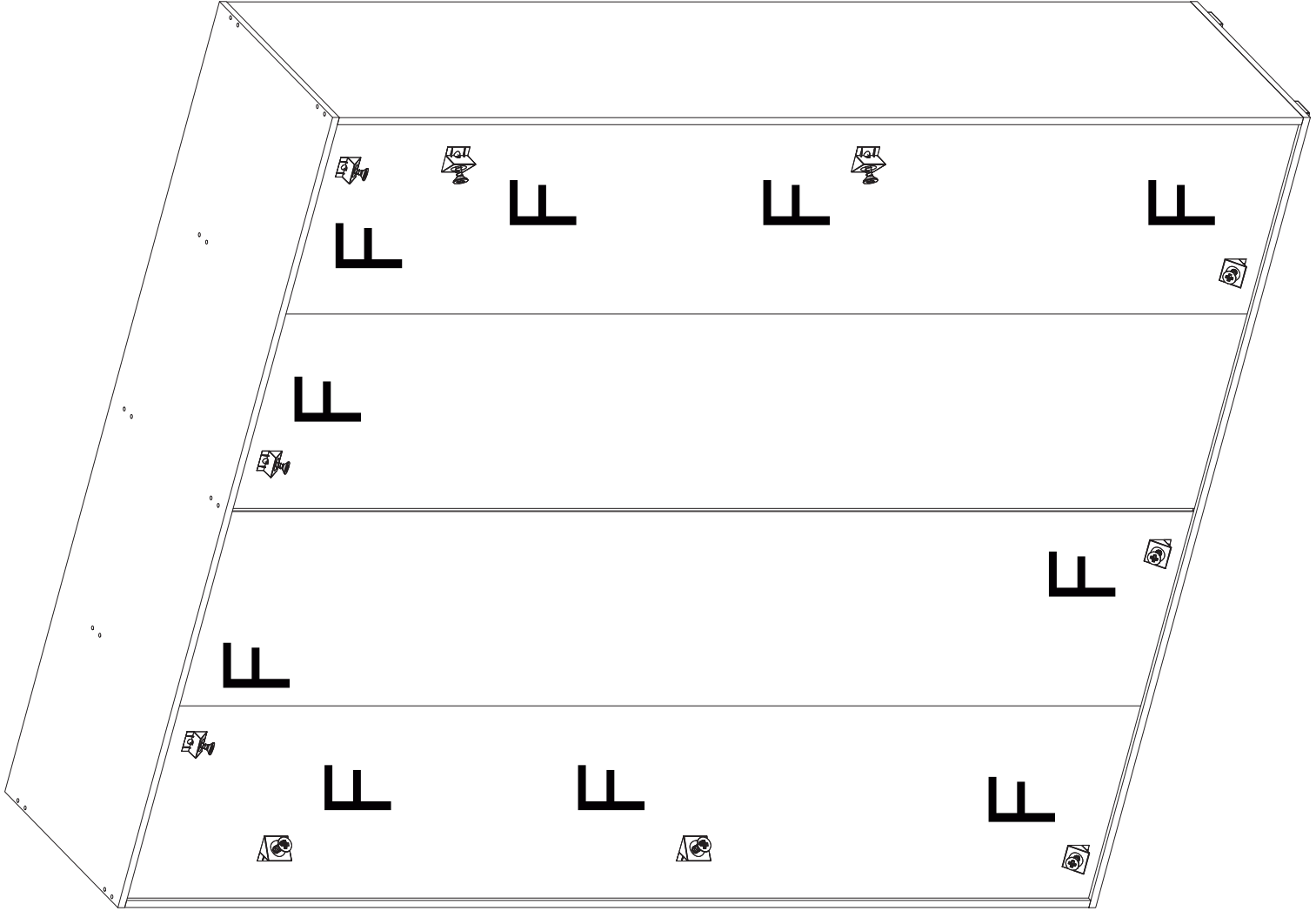

# 11

V3525 x6

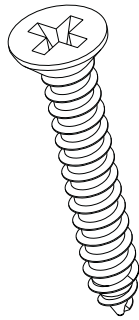

Ø3.5x25 mm.

L

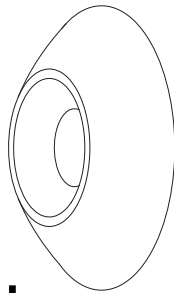

x6

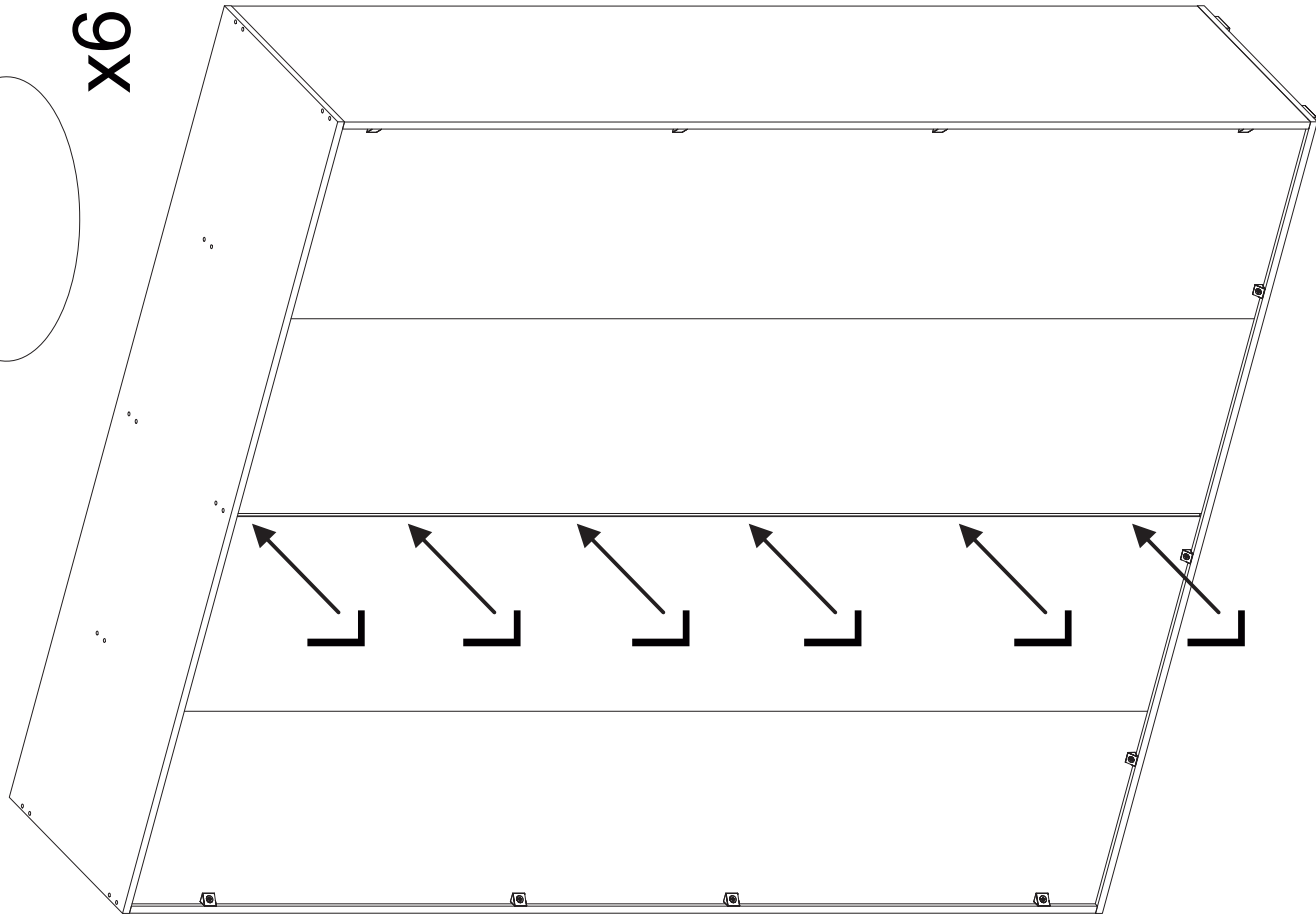

L

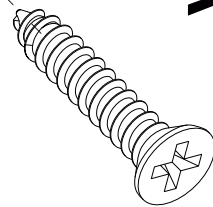
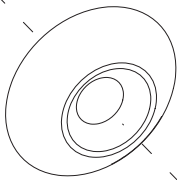

V3525

60TR



60SCH

60SCH

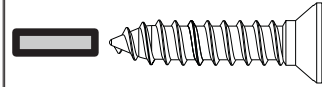

V3525

TUB

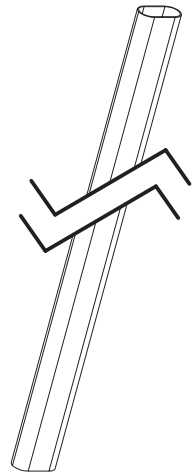

x3

RT

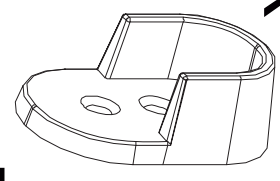

x6

V3516 x12

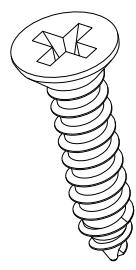

Ø3.5x16 mm.

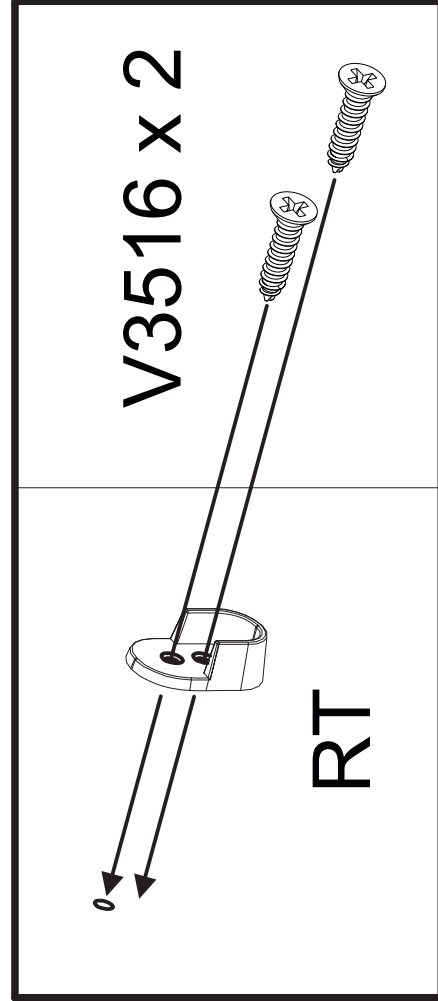
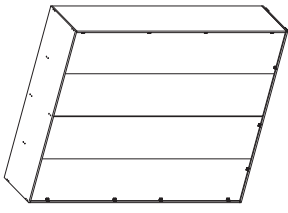
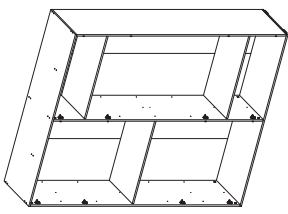

V3516 x 2

RT

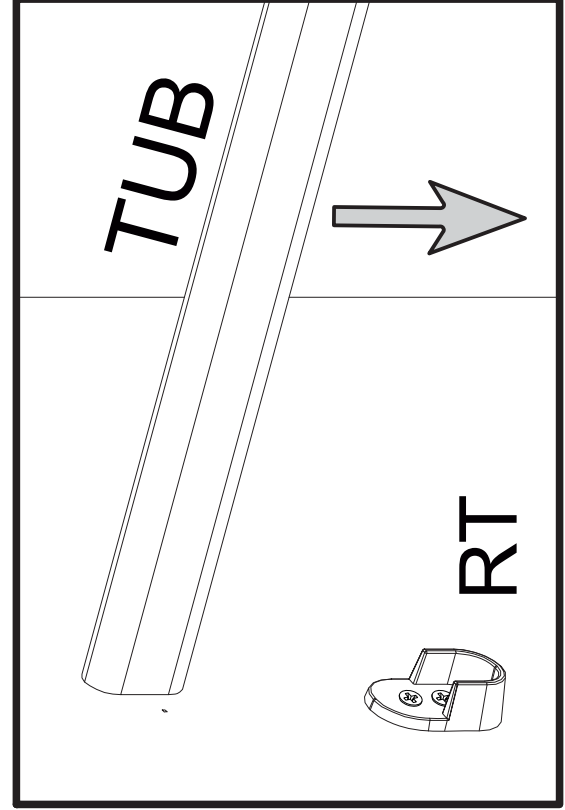

TUB

RT

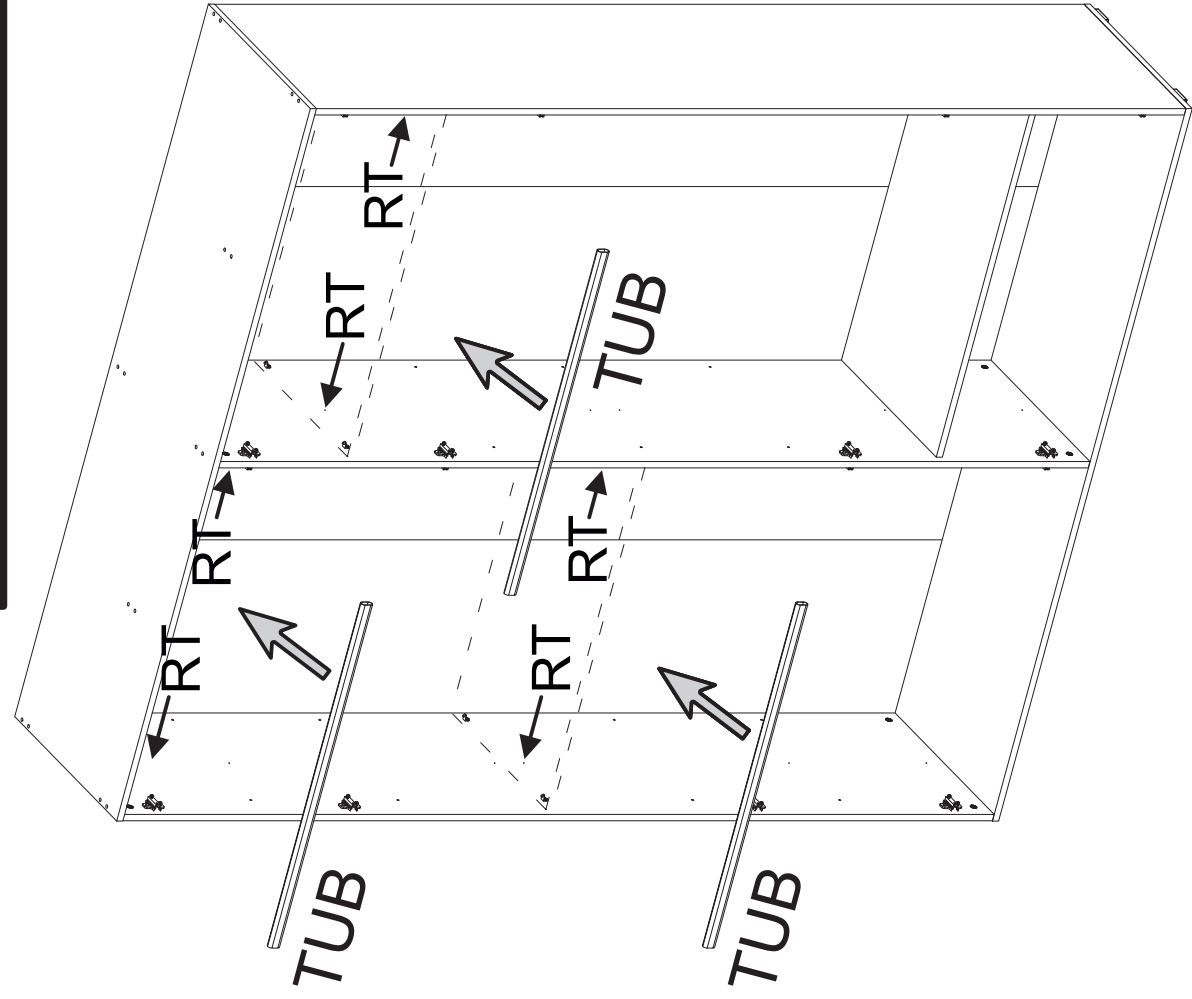

# 13

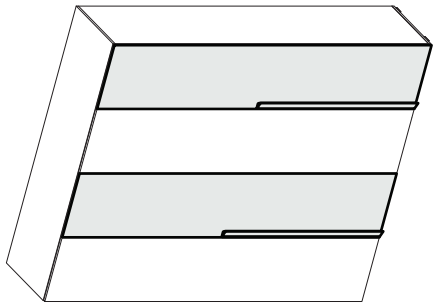

C8

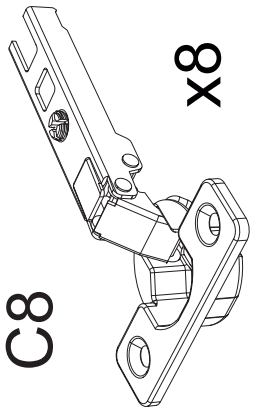

x8

V415 x16

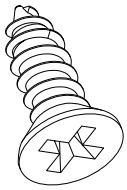

ø4x15 mm

T422 x8

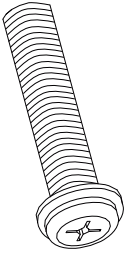

ø4x22.5 mm

G

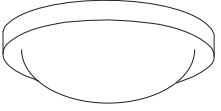

x4

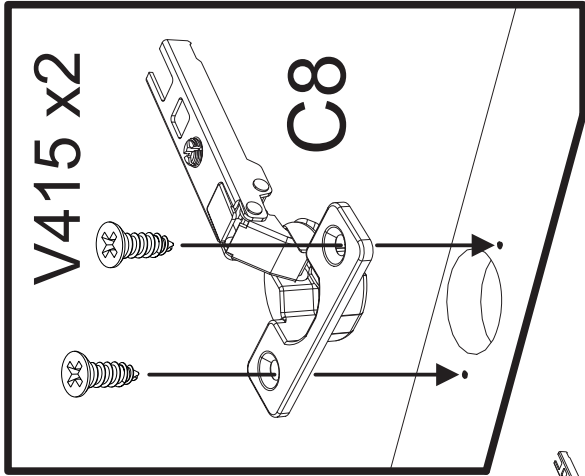

V415 x2

C8

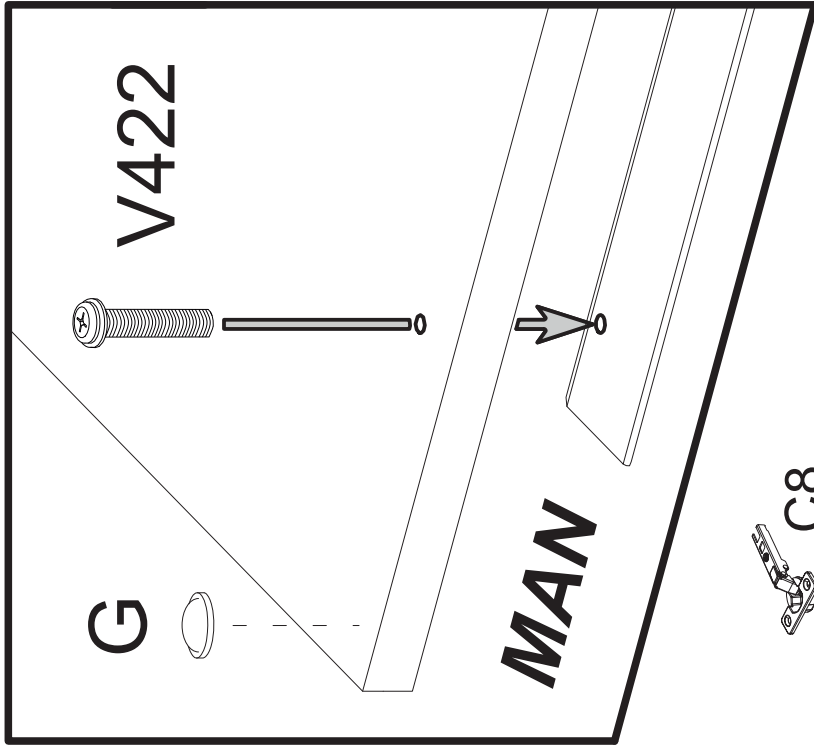

G

V422

MAN

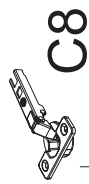

C8

G

V422

V422

V422

V422

60SP x 2



C8

C8

G

MAN

14

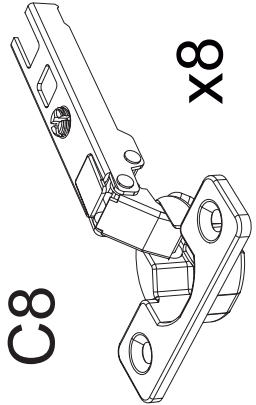
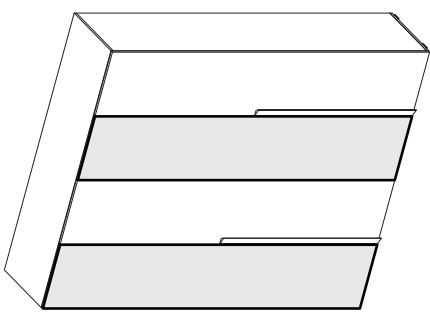

C8

x8

V415 x16

G

x4

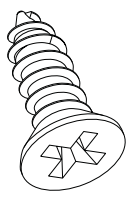
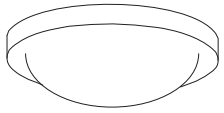

ø4x15 mm

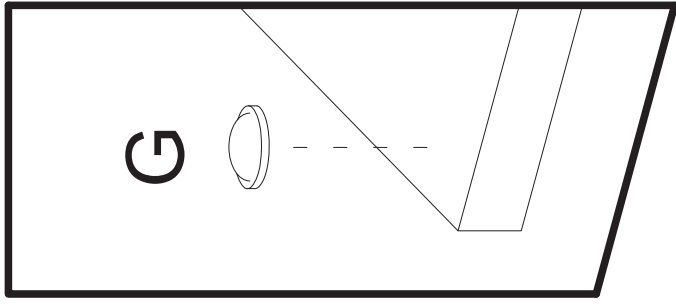

G

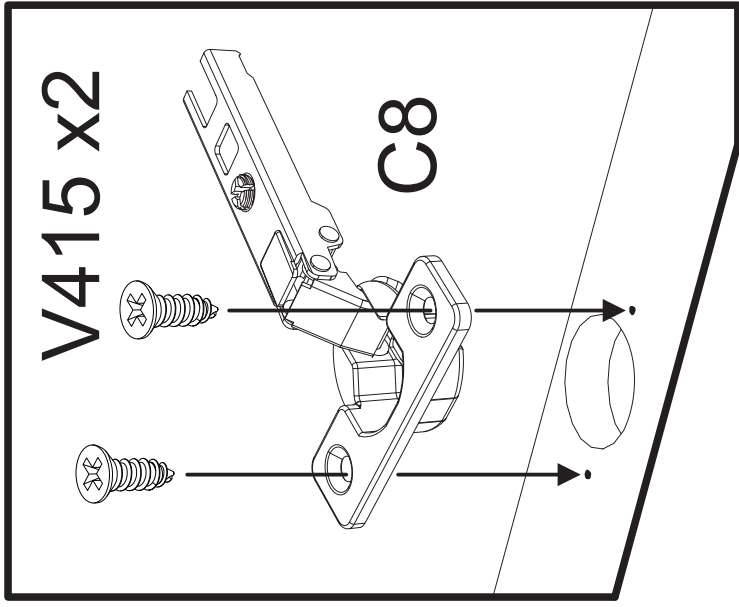

V415 x2

C8



C8



C8



C8



C8

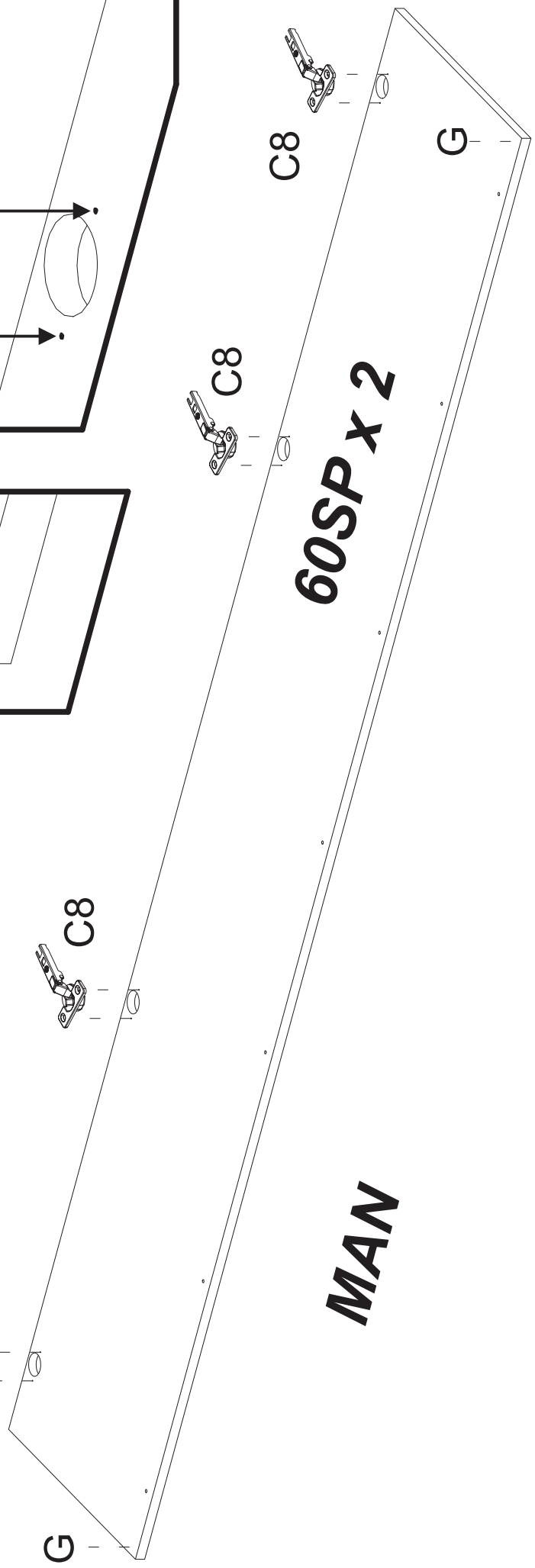

60SP x 2

MAN

G

G

15

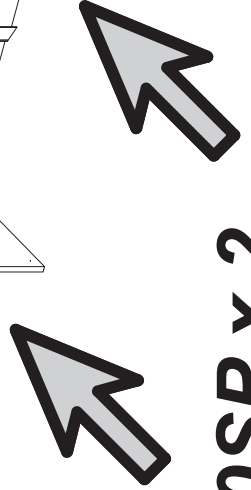
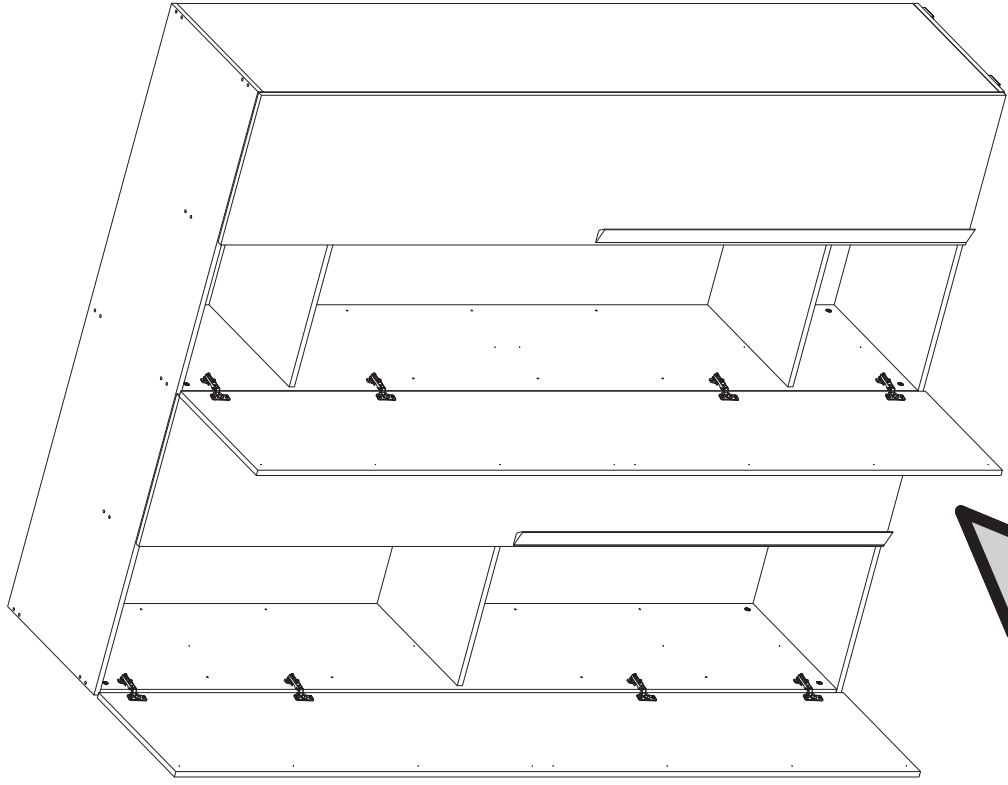
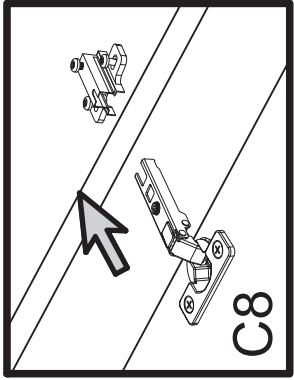
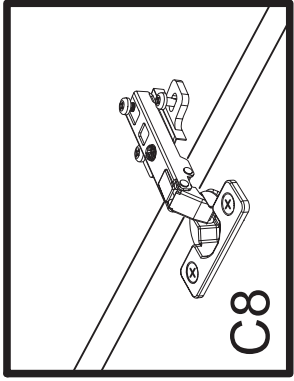

60SP x 2

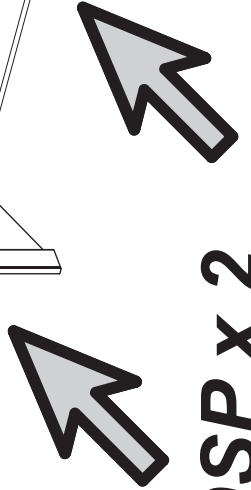
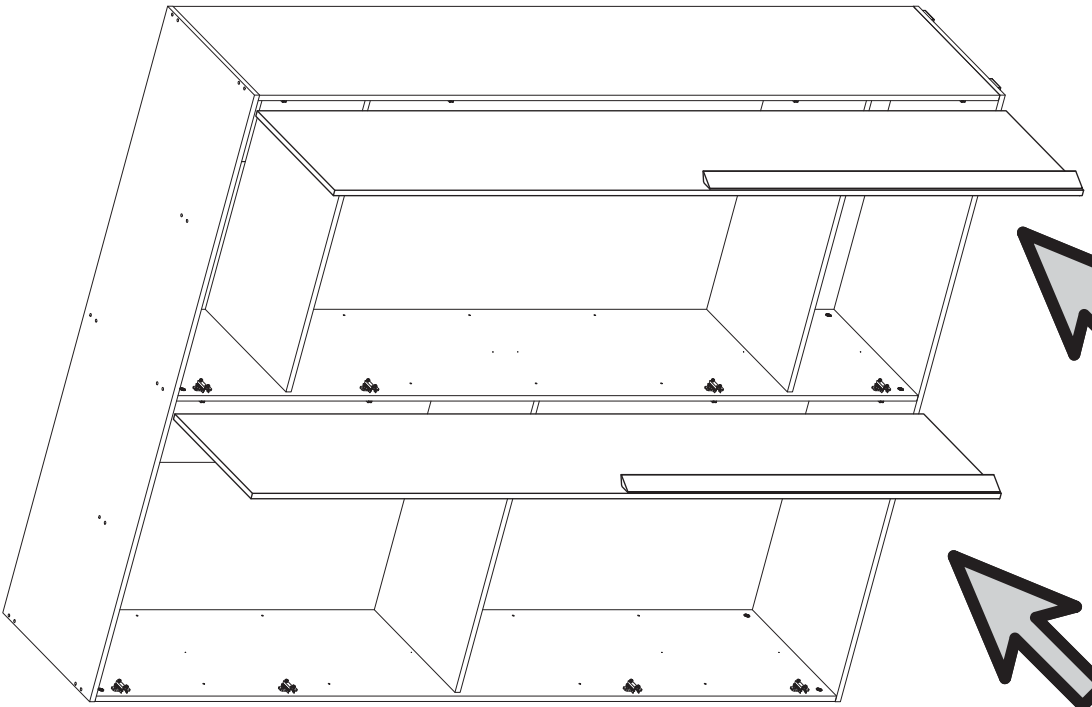

60SP x 2

16

V3516 x2

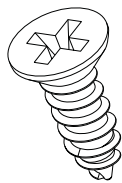

PST x1

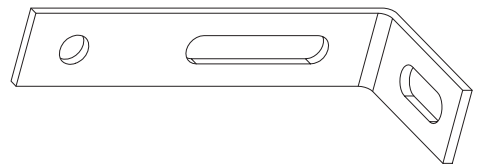

PST

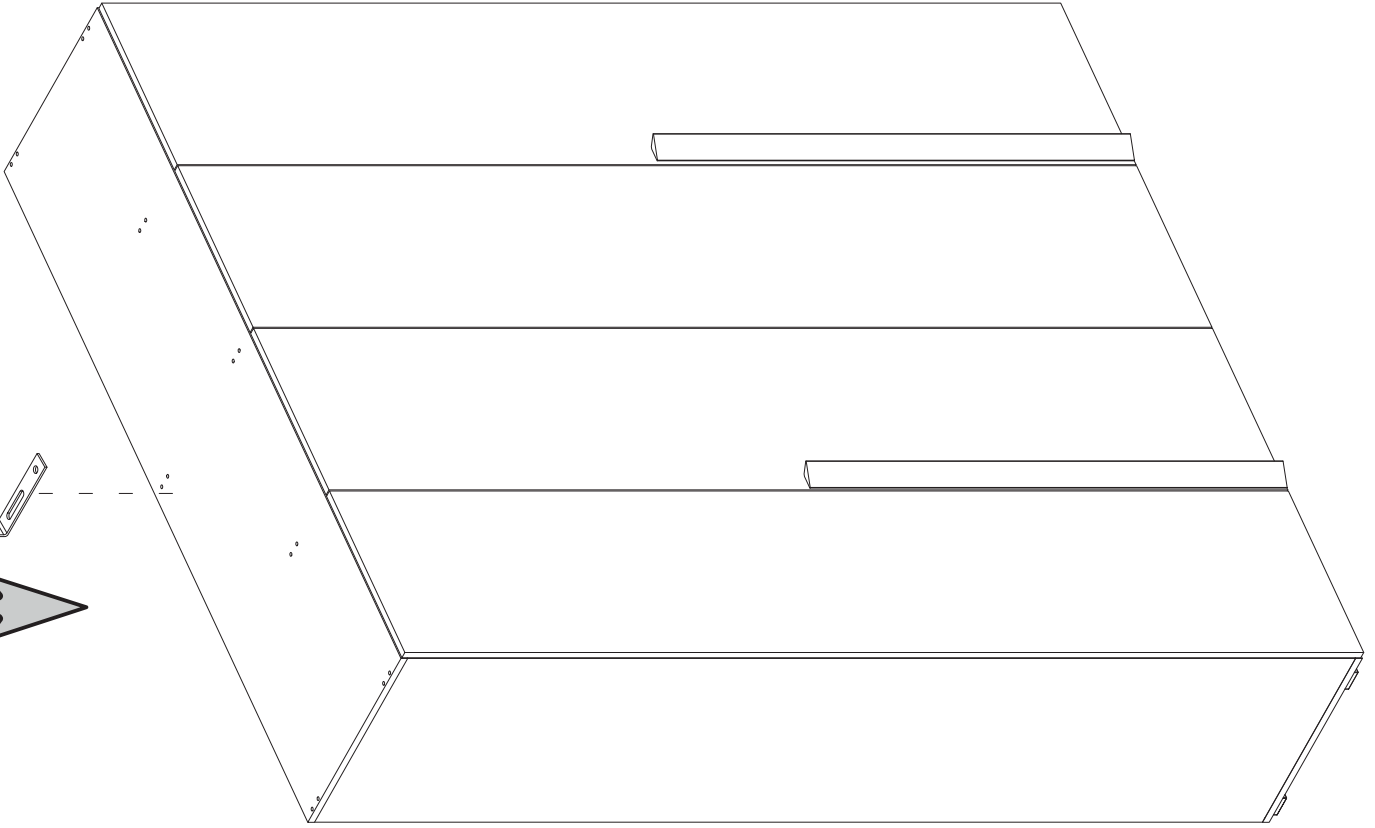
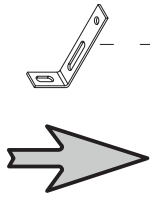

PST

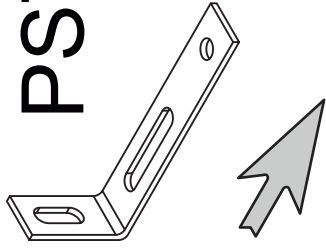

40CI

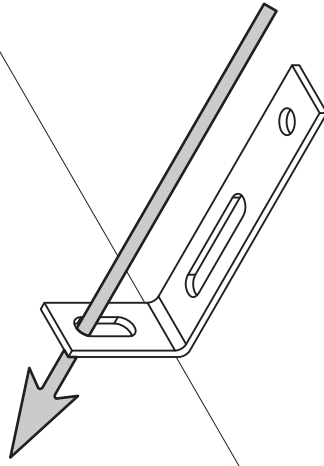

V3516

x 2

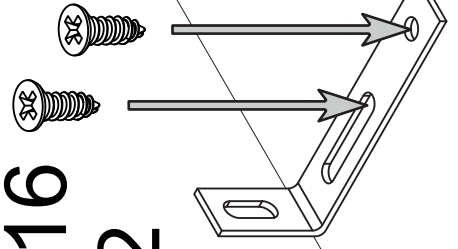

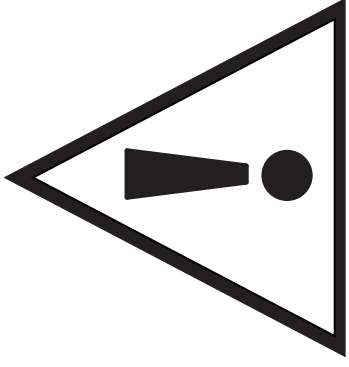

Gentile Cliente

Il montaggio dei pensili deve essere effettuato da personale competente.

I tasselli di fissaggio non sono compresi nella ferramenta.

Scegliere il tipo di tassello per il fissaggio più adatto alla tipologia di muro. Assicurarsi l'idoneità della parete per un sostegno sicuro del pensile.

Dear Customer,

The assembling of the hanging elements must be done by a competent staff. The wall plugs are not included in the hardware package.

Choose the wall plugs more suitable to the type of the wall.

Ensure the suitability of the wall for a secure support of the hanging element.

Sehr geehrter Kunde, die Montage der Hängeelemente muss von Fachpersonal ausgeführt werden!

Bitte verwenden Sie eigene Dübel, die der Beschaffenheit der Wand entsprechen. Zu Ihrer eigenen Sicherheit legen wir dem Beschlagbeutel keine Dübel bei.

Cher client, les éléments muraux ne peuvent être installés que par du personnel qualifié !

Veillez utiliser vos propres ancrages adaptés à la nature du mur.

Pour votre sécurité, nous n'incluons pas de chevilles dans le matériel.

Estimado cliente, el montaje de los

muebles colgados en la pared debe ser realizado por personal competente. Los tacos de fijación no están incluidos

en la bolsa de herrajes. Elija el tipo de anclaje de fijación que mejor se

adapte al tipo de pared. Asegúrese de que la pared sea adecuada para un soporte seguro del mueble colgado en la pared.