

EN_IMPORTANT, RETAIN FOR FUTURE REFERENCE: READ CAREFULLY.

FR_IMPORTANT: A LIRE ATTENTIVEMENT ET À CONSERVER POUR CONSULTATION ULTÉRIEURE.

ES_IMPORTANTE, LEA Y GUARDE PARA FUTURAS REFERENCIAS.

PT_IMPORTANTE, RETER PARA REFERÊNCIA FUTURA: LEIA ATENTAMENTE.

DE_WICHTIG! SORGFÄLTIG LESEN UND FÜR SPÄTER NACHSCHLAGEN AUFBEWAHREN.

IT_IMPORTANTE! CONSERVARE IL PRESENTE MANUALE PER FUTURO RIFERIMENTO E LEGGERLO ATTENTAMENTE.

EN

1. Do not modify the trailer.
2. Always check all parts of the trailer are secure, tight and properly connected.
3. Do not lift the trailer up when the pet is inside.
4. The brakes must be used when the trailer is kept stationary.
5. Never use the trailer on uneven ground.
6. Never park the trailer near dangerous and busy roads.
7. The rider must wear an approved safety helmet.
8. Check the air pressure before every trip.
9. Be careful whilst riding in traffic, especially when turning corners and riding up and down slopes.
10. Do not store or use this trailer in areas exposed to high or low temperatures or humidity for prolonged periods.

FR

1. Ne modifiez pas techniquement la remorque.
2. Vérifiez toujours que toutes les parties de la remorque sont bien connectées correctement.
3. Ne soulevez pas la remorque lorsque l'animal est à l'état.
4. Il faut utiliser les freins lorsque vous arrêtez de déplacer votre remorque.
5. N'utilisez jamais la remorque sur un terrain inégal.
6. Ne garez jamais la remorque près d'une route dangereuse.
7. Le conducteur doit porter des casques de sécurité homologués.
8. Vérifiez la pression d'air avant chaque voyage.
9. Soyez prudent tout en conduisant dans la circulation en particulier les virages et les pentes.
10. Ne stockez pas ou utilisez cette remorque dans les zones exposées à des températures ou à une humidité élevées ou basses pendant une longue période.

ES

1. No modifique el remolque técnicamente.
2. Siempre inspeccione que todas las partes del remolque estén conectadas de manera correcta y firme.
3. No levante el remolque cuando la mascota esté adentro.
4. Debe utilizar los frenos cuando deje de mover su remolque.
5. Nunca utilice el remolque en un lugar irregular.
6. Nunca estacione el remolque cerca de una carretera peligrosa.
7. El ciclista debe usar cascos de seguridad aprobados.
8. Compruebe la presión del aire antes de cada viaje.
9. Tenga cuidado al circular por el tráfico, especialmente en curvas y pendientes.
10. No almacene ni utilice el remolque en áreas expuestas a altas o bajas temperaturas o húmedas durante largo tiempo.

PT

1. Não modificar o reboque.
2. Verificar sempre se todas as partes do reboque estão seguras, apertadas e devidamente conectadas.
3. Não levantar o reboque quando o animal de estimação estiver no interior.
4. Os travões devem ser usados quando o reboque é mantido parado.
5. Nunca utilizar o reboque em terrenos irregulares.
6. Nunca estacionar o reboque perto de estradas perigosas e movimentadas.
7. O condutor deve usar um capacete de segurança aprovado.
7. Verificar a pressão do ar antes de cada passeio.
8. Ter cuidado ao circular no trânsito, especialmente ao virar esquinas e subir e descer declives.
9. Não armazenar ou utilizar este reboque em áreas expostas a temperaturas altas ou baixas ou humidade durante períodos prolongados.

DE

1. Nehmen Sie keine technischen Änderungen am Anhänger vor.
2. Überprüfen Sie immer, ob alle Teile des Anhängers richtig angeschlossen und befestigt sind.
3. Heben Sie den Anhänger nicht an, wenn sich das Haustier darin befindet.
4. Betätigen Sie die Bremsen, wenn Sie Ihren Anhänger nicht mehr bewegen.
5. Nutzen Sie den Anhänger niemals an unebenen Stellen.
6. Parken Sie den Anhänger niemals in der Nähe einer gefährlichen Straße.
7. Der Fahrer sollte zugelassene Schutzhelme tragen.
8. Überprüfen Sie den Luftdruck vor jeder Fahrt.
9. Seien Sie vorsichtig, wenn Sie im Verkehr fahren, insbesondere in Kurven und in der Steigung.
10. Lagern oder verwenden Sie diesen Anhänger nicht in Bereichen, die längere Zeit hohen oder niedrigen Temperatur oder Luftfeuchtigkeit ausgesetzt sind.

IT

1. Non modificare il rimorchio tecnicamente.
2. Controllare sempre che tutte le parti del rimorchio siano connesse correttamente e strette in sicurezza.
3. Non sollevare il rimorchio quando l'animale si trova al suo interno.
4. È necessario utilizzare i freni quando si desidera arrestare il rimorchio mentre lo si sta spostando.
5. Non utilizzare mai il rimorchio su un terreno irregolare.
6. Non parcheggiare mai il rimorchio vicino a strade pericolose.
7. L'utente alla guida deve indossare un elmetto di sicurezza omologato.
8. Controllare la pressione dell'aria prima di ogni uscita.
9. Fare attenzione se si guida nel traffico, in particolare in caso di curve pericolose e pendii.
10. Non conservare o utilizzare questo rimorchio a lungo in aree soggette a temperature particolarmente alte o basse, o in caso di umidità.

A x 1

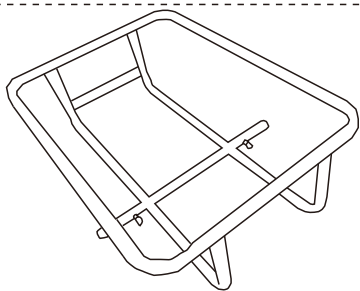

B x 2

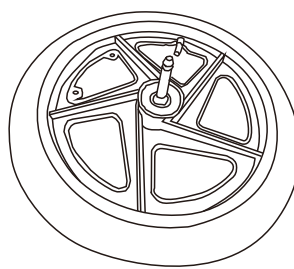

C x 1

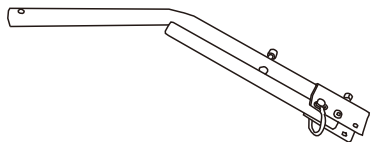

D x 1

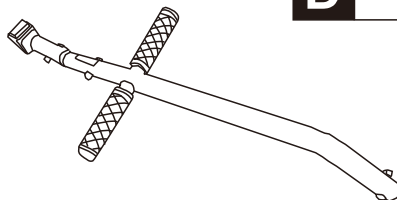

E x 1

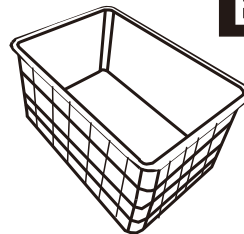

F x 1

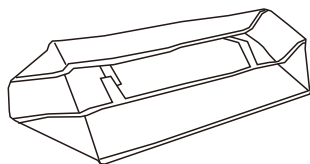

G x 1

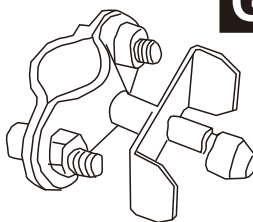

H x 1

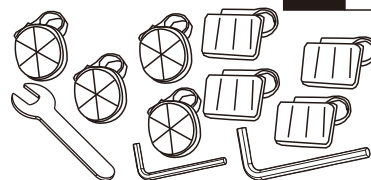

A x 1



B x 2



01

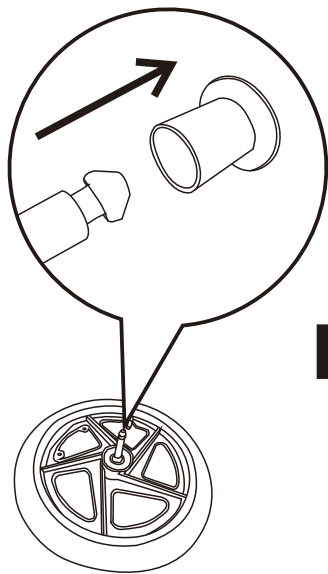
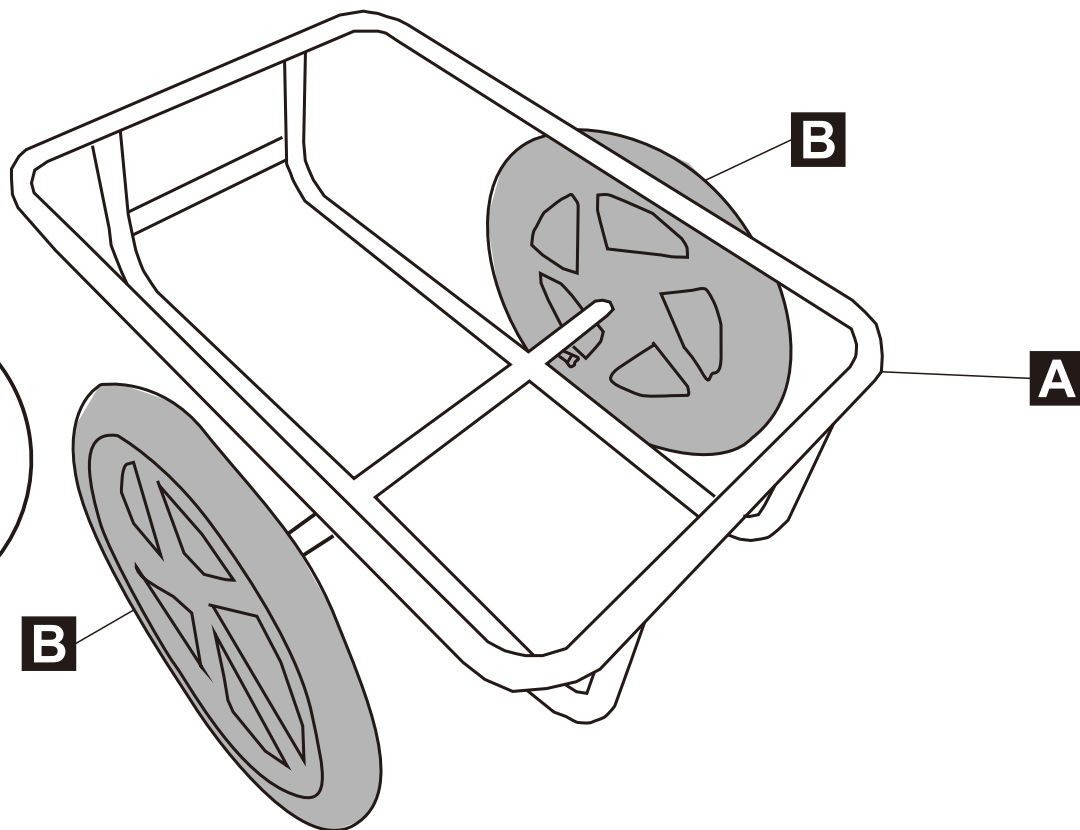

C x 1

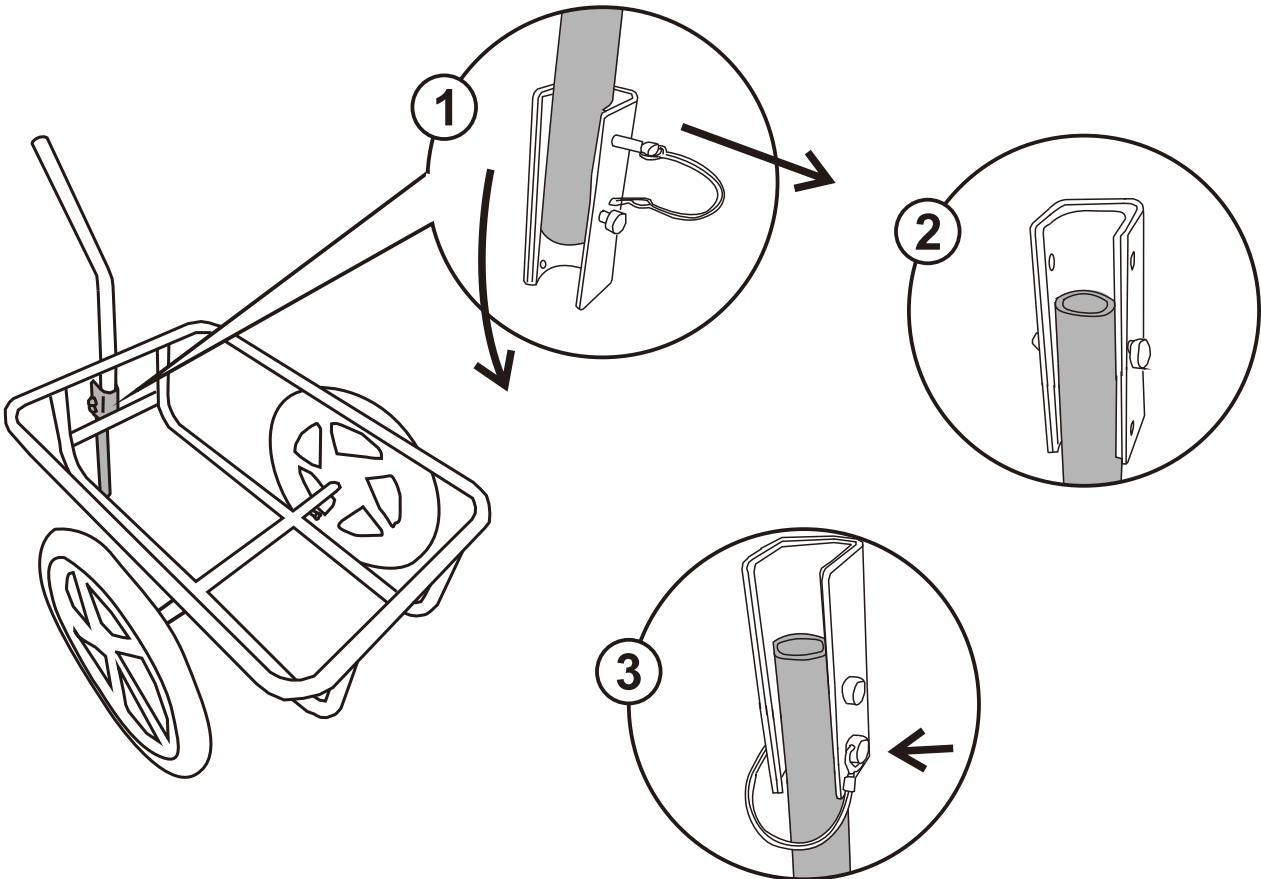
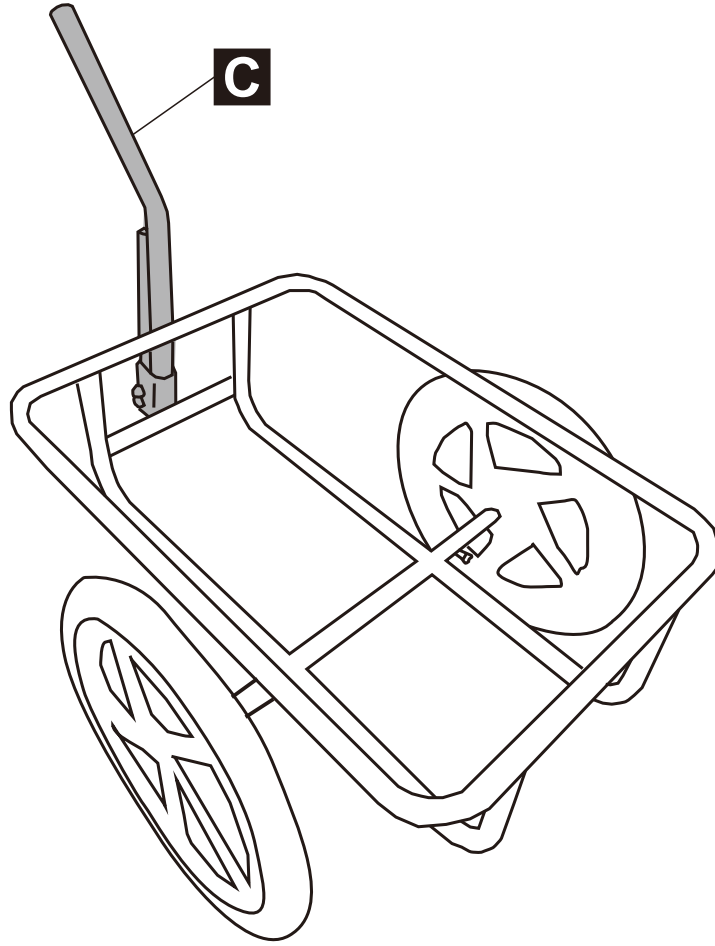
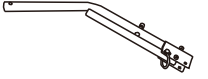

D x 1

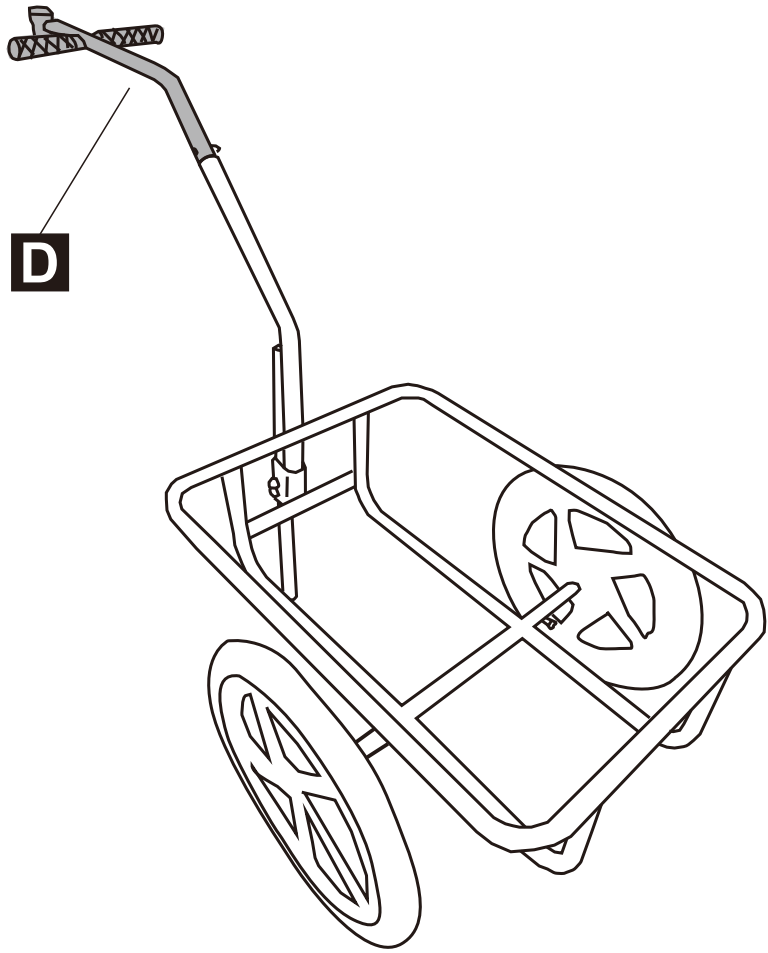

E x 1

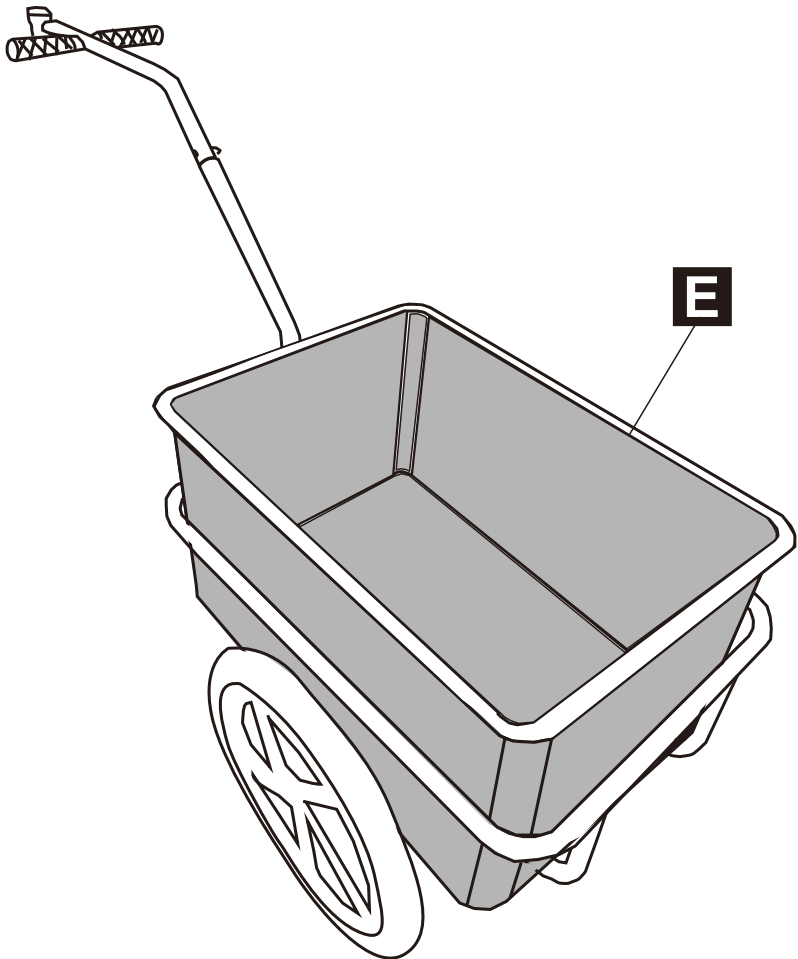

F x 1

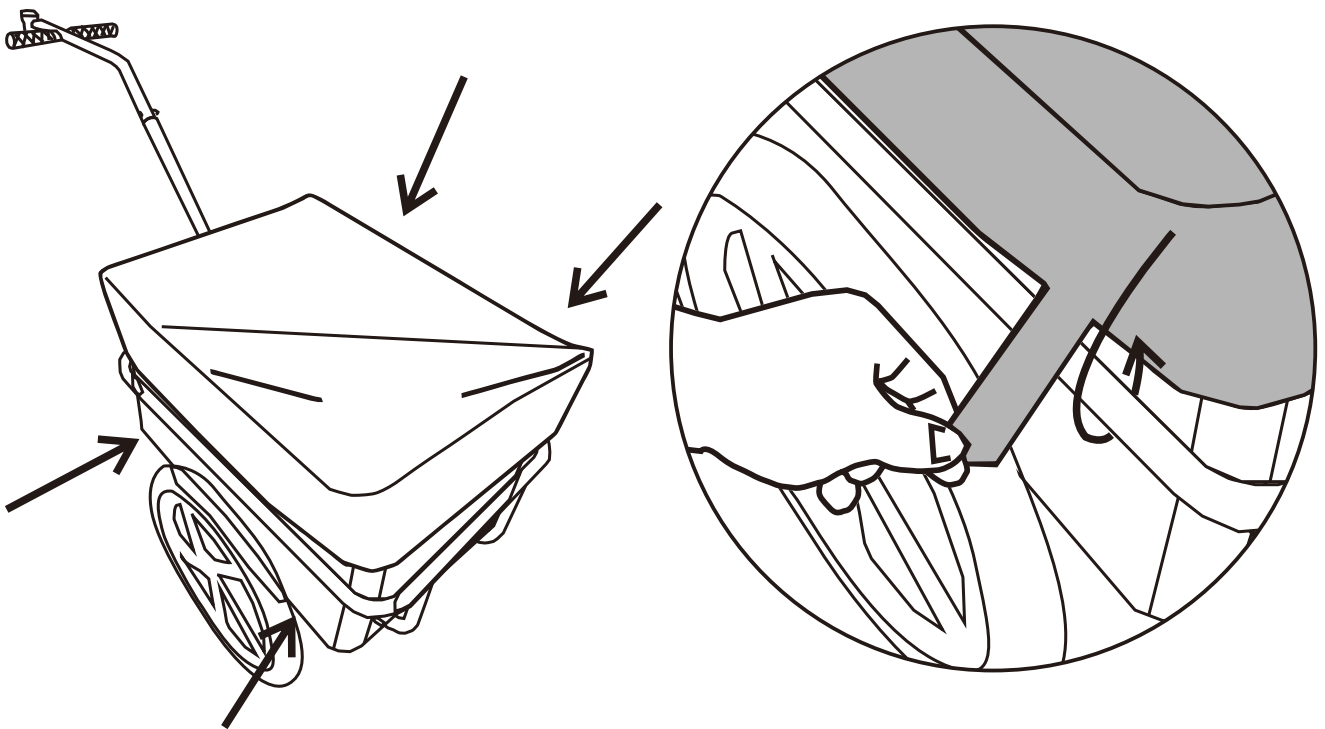
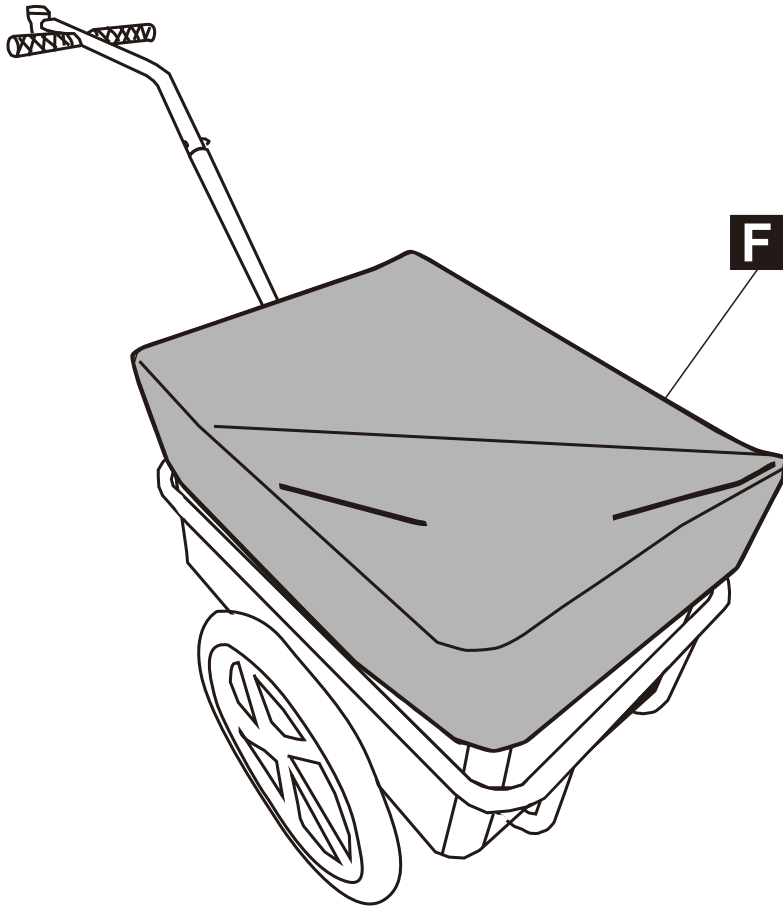
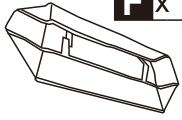

H x 1

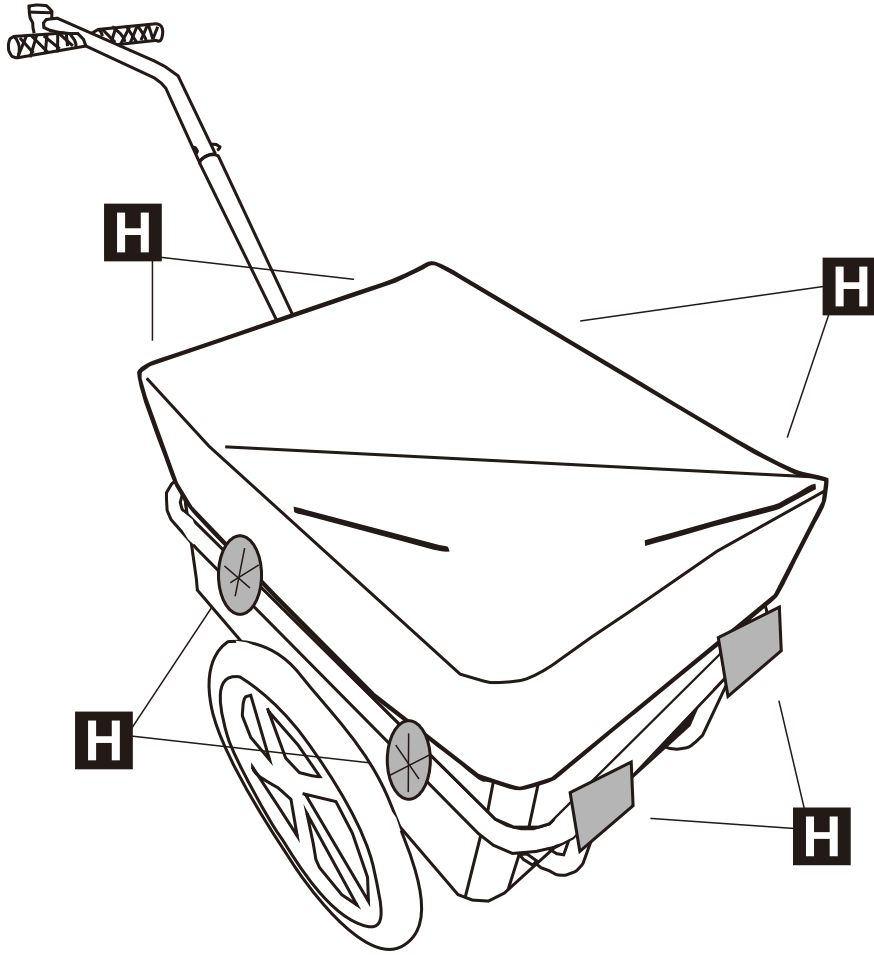
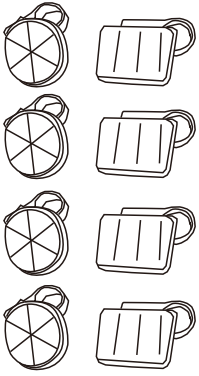

G x 1

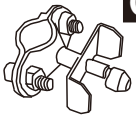

Done

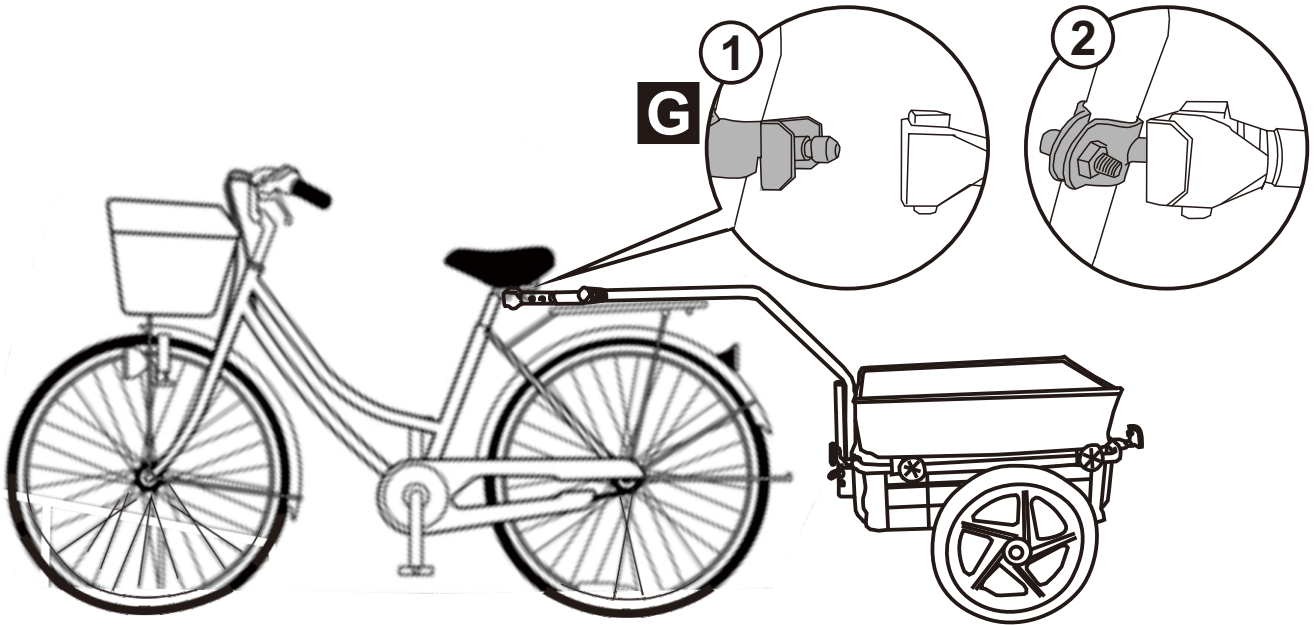

If you have any questions, please contact our customer care center, Our contact details are below:

US

 001-877-644-9366

 customerservice@aosom.com

Imported by Aosom LLC
27150 SW Kinsman Rd Wilsonville, OR 97070 USA
MADE IN CHINA

If you have any questions, please contact our customer care center, Our contact details are below:

CA

 416-792-6088

 customerservice@aosom.ca

Imported by Aosom Canada Inc.
7270 Woodbine Avenue, Unit 307, Markham,
Ontario Canada L3R 4B9
MADE IN CHINA

Si vous avez la moindre question, veuillez contacter notre centre d'assistance à la clientèle, Nos coordonnées sont les suivantes:

 416-792-6088

 customerservice@aosom.ca

Importé par Aosom Canada Inc.
7270 Woodbine Avenue, unité 307,
Markham, Ontario Canada L3R 4B9
FABRIQUÉ EN CHINE

If you have any questions, please contact our customer care center, Our contact details are below:

UK

 0044-800-240-4004

 enquiries@mhstar.co.uk

IMPORTER ADDRESS:
MH STAR UK LTD
Unit 27, Perivale Park,
Horsenden lane South
Perivale, UB6 7RH
MADE IN CHINA

Si vous avez la moindre question, veuillez contacter notre centre d'assistance à la clientèle, Nos coordonnées sont les suivantes:

FR

 0033-1-84166106

 aosom@mhfrance.fr

Importé par/Fabricant/REP:
MH FRANCE
2 Rue Maurice Hartmann
92130 Issy Les Moulineaux
France
FABRIQUÉ EN CHINE

Wenn Sie Fragen haben, wenden Sie sich bitte an unser Kundendienstzentrum, Unsere Kontaktdaten stehen unten:

DE

 0049-0(40)-87408465

 service@aosom.de

ADRESSE DES IMPORTEURE/Hersteller/REP:
MH Handel GmbH
Wendenstraße 309
D-20537 Hamburg
Germany
IN CHINA HERGESTELLT

In caso di dubbio, si prega di contattare il nostro centro assistenza clienti, I nostri dettagli di contatto sono di seguito:

IT

 0039-0249471447

 clienti@aosom.it

IMPORTATO DA/Produttore/REP:
AOSOM Italy srl
Centro Direzionale Milanofiori
Strada 1 Palazzo F1
20057 Assago (MI)
P.I.: 08567220960
FATTO IN CINA

Si tiene alguna pregunta, comuníquese con nuestro Centro de Atención al Cliente, Nuestros datos de contacto son los siguientes:

ES

 0034-931294512

 atencioncliente@aosom.es

IMPORTADOR/Fabricante/REP:
SPANISH AOSOM, S.L.
C/ROC GROS, N°15.08550, ELS HOSTALETS DE
BALENYÀ, SPAIN.
B66295775
HECHO EN CHINA

Se tiver alguma dúvida, por favor contacte o nosso Centro de Atendimento ao Cliente, Os nossos dados de contacto são os seguintes:

 0034-931294512

 info@aosom.pt.

IMPORTADOR/Fabricante/REP:
SPANISH AOSOM, S.L.
C.ROC GROS N.15, 08550. ELS HOSTALETS DE
BALENYÀ
FEITO NA CHINA



FR

**DONNEZ
OU
RECYCLEZ**



ASSOCIATION

OU



LIVRAISON

OU



DÉCHÈTERIE

Adresses sur quefairedemesdechets.fr